

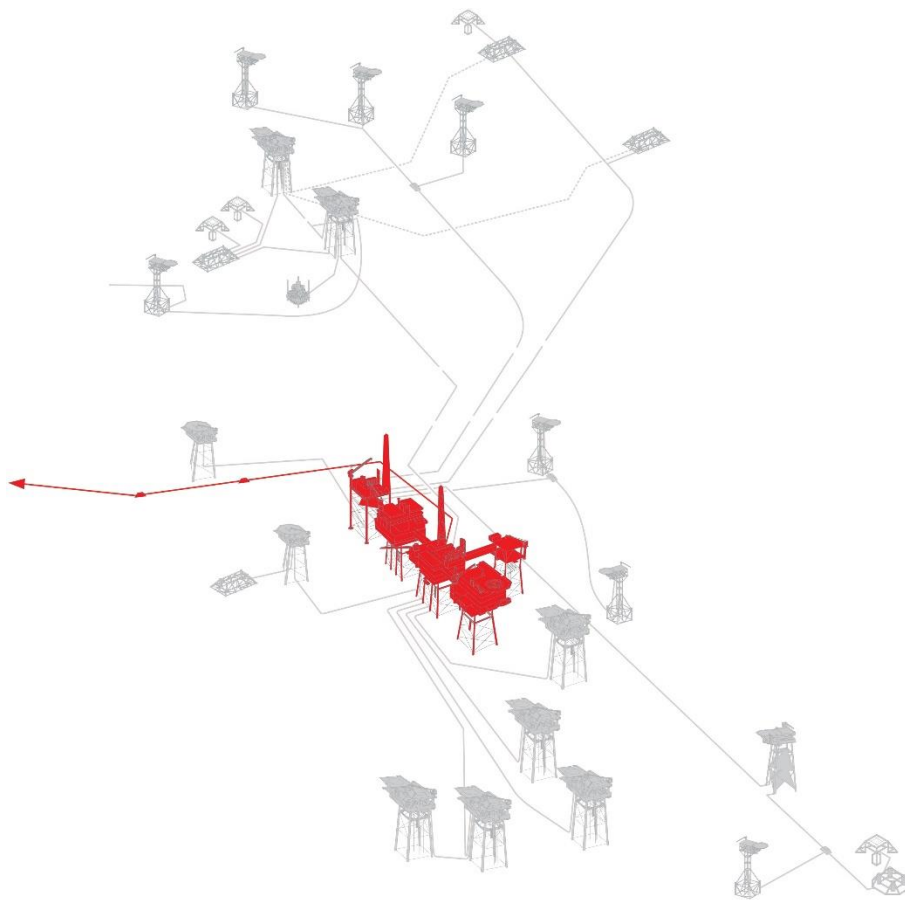

CHRYSAOR



Decommissioning Programmes LOGGS Installation & North Valiant PD

LOGGS PR, LOGGS PC, LOGGS PP, LOGGS PA, North Valiant PD, & Associated Pipelines

DOCUMENT CONTROL

Document Number		CYR-SNS-L-XX-P-PM-12-00002	
Document Classification		Public	
Document Ownership		Decommissioning	
Prepared by	S. Axon	Date: 16/09/20	S. Axon
Reviewed by	C. Marston	Date: 16/09/20	C. Marston
Approved by	R. Tocher	Date: 16/09/20	R. Tocher

REVISION RECORD

Revision No	Description of Revision	Date
1	Issued for Internal Review	05/06/20
2	Updated and re-issued	20/06/20
3	Issued to OPRED review and comment	30/06/20
4	Issued for Statutory Consultation	16/09/20

DISTRIBUTION

Name	Position	Company	No. of Copies
R. Tocher	Decommissioning Mgr	Chrysaor Production (U.K.) Limited	1 electronic
L. Harpley	Business Manager	BP Exploration Operating Company Ltd	1 electronic
F. Livingston	Senior Decommissioning Mgr	OPRED	1 electronic
I. Rowe	General Manager	NFFO	1 electronic
S. Alexander	Managing Director	SFF	1 electronic
R. James	Secretary	NIFPO	1 electronic
A. Riddell	Permitting Manager	Global Marine Group	1 electronic
	Head Librarian	Great Yarmouth Community Library	1 hardcopy

TABLE OF CONTENTS

<i>INST = Installations; P/L = Pipelines</i>		INST	P/L
1	EXECUTIVE SUMMARY 8		
1.1	COMBINED DECOMMISSIONING PROGRAMMES 8	✓	✓
1.2	REQUIREMENT FOR DECOMMISSIONING PROGRAMMES 8	✓	✓
1.3	INTRODUCTION..... 8	✓	✓
1.4	DECOMMISSIONING OVERVIEW 12	✓	✓
1.5	SUMMARY OF PROPOSED DECOMMISSIONING PROGRAMMES 15	✓	✓
1.6	FIELD LOCATION INCLUDING FIELD LAYOUT AND ADJACENT FACILITIES 16	✓	✓
1.7	INDUSTRIAL IMPLICATIONS 22	✓	✓
2	DESCRIPTION OF ITEMS TO BE DECOMMISSIONED..... 23	✓	
2.1	SURFACE FACILITIES (TOPSIDES AND JACKETS)..... 23	✓	
2.2	PIPELINES INCLUDING STABILISATION FEATURES 29	✓	✓
2.3	RISERS..... 30	✓	
2.4	WELLS..... 41	✓	✓
2.5	INVENTORY ESTIMATES 42	✓	
3	REMOVAL AND DISPOSAL METHODS..... 43	✓	
3.1	TOPSIDES DECOMMISSIONING..... 43	✓	
3.2	JACKET DECOMMISSIONING 48	✓	✓
3.3	PIPELINES..... 56		✓
3.4	PIPELINE PROTECTION STRUCTURES & STABILISATION FEATURES 57		✓
3.5	PIPELINE PROTECTION & STABILISATION FEATURES..... 58		✓
3.6	WELLS..... 59	✓	✓
3.7	WASTE STREAMS..... 59	✓	✓
4	ENVIRONMENTAL APPRAISAL OVERVIEW 60	✓	✓
4.1	ENVIRONMENTAL SENSITIVITIES (SUMMARY) 60	✓	✓
4.2	POTENTIAL ENVIRONMENTAL IMPACTS AND THEIR MANAGEMENT 64	✓	✓
5	INTERESTED PARTY CONSULTATIONS 67	✓	✓
6	PROGRAMME MANAGEMENT..... 68	✓	✓
6.1	PROJECT MANAGEMENT AND VERIFICATION 68	✓	✓
6.2	POST-DECOMMISSIONING DEBRIS CLEARANCE AND VERIFICATION 68	✓	✓
6.3	SCHEDULE 68	✓	✓
6.4	COSTS..... 70	✓	✓
6.5	CLOSE OUT 70	✓	✓
6.6	POST DECOMMISSIONING MONITORING AND EVALUATION 70	✓	✓
7	SUPPORTING DOCUMENTS 71	✓	✓
APPENDIX 1	PIPELINE BURIAL PROFILES 72		✓
APPENDIX 1.1	PL454 SEABED & BURIAL PROFILE (2010)..... 72		✓
APPENDIX 2	DECOMMISSIONING ONSHORE PIPELINES 74		✓
APPENDIX 2.1	OUTLINE APPROACH 74	✓	✓
APPENDIX 3	PUBLIC & CONSULTEE CORRESPONDENCE 76	✓	✓
APPENDIX 3.1	PUBLIC NOTICES..... 76	✓	✓
APPENDIX 3.2	CORRESPONDENCE WITH STATUTORY CONSULTEES..... 76	✓	✓
APPENDIX 4	PARTNER LETTERS OF SUPPORT 77		

FIGURES AND TABLES

Figure 1.3.1: LOGGS Installation – Pipelines	9
Figure 1.6.1: LOGGS Installation Location in UKCS	16
Figure 1.6.2: LOGGS Installation Layout	17
Figure 1.6.3: Adjacent Facilities (LOGGS Installation and pipelines in red)	20
Figure 1.6.4: Adjacent Facilities in relation to non-oil and gas features and infrastructure)	21
Figure 2.1.1: Illustration Showing the Layout of the LOGGS Installation	24
Figure 2.1.2: Photograph of the LOGGS Installation, View Looking South-East	25
Figure 2.1.3: Photograph of the LOGGS Installation, View Looking North	25
Figure 2.1.4: Photograph of LOGGS PR	26
Figure 2.1.5: Photograph of LOGGS PC	26
Figure 2.1.6: Photograph of LOGGS PP	27
Figure 2.1.7: Photograph of LOGGS PA	27
Figure 2.1.8: Photograph of North Valiant (1) PD	28
Figure 2.3.1: Pipeline Crossings & Deposited Rock (as surveyed 2010)	32
Figure 2.3.2: Schematic Branch Tee No. 1	33
Figure 2.3.3: Schematic Branch Tee No. 2	34
Figure 2.3.4: Pipeline Crossing PL454 & PL455 over PL253	35
Figure 2.3.5: Pipeline Crossing PL454 & PL455 over PL27 & PL161	36
Figure 2.3.6: PL454 & PL455 underneath Third-Party Pipelines at LOGGS PR	37
Figure 2.3.7: Approaches & Pipelines LOGGS PP North Side	38
Figure 2.5.1: Pie-chart of estimated installation inventory	42
Figure 2.5.2: Pie-chart of estimated pipeline inventory, excluding deposited rock	42
Figure 3.1.1: View on LOGGS PR Topsides Looking North	44
Figure 3.1.2: View on LOGGS PC Topsides Looking North & West	44
Figure 3.1.3: View on LOGGS PP Topsides Looking North & West	45
Figure 3.1.5: View on North Valiant PD Topsides Looking West & South	46
Figure 3.2.1: LOGGS PR Jacket Typical View	48
Figure 3.2.2: LOGGS PC Jacket View Looking West	49
Figure 3.2.3: LOGGS PC Jacket View Looking North	50
Figure 3.2.4: LOGGS PP Jacket View Looking West	51
Figure 3.2.5: LOGGS PP Jacket View Looking North	52
Figure 3.2.6: LOGGS PA Jacket Typical View	53
Figure 3.2.7: North Valiant PD Jacket View Looking North	54
Figure 3.2.8: North Valiant PD Jacket View Looking East	55
Figure A1.1.1: PL454 Seabed & Burial Profile (2010-2018)	72
Figure A1.1.2: PL454 Depth of Cover Profile (2010-2018) ¹¹	73
Figure A2.1.1: PL454 Theddlethorpe Approach (indicative only)	74
Table 1.4.1 Installations Being Decommissioned	12
Table 1.4.2: Installation Section 29 Notice Holders Details – LOGGS PR, PC, PP & PA	13
Table 1.4.3: Installation Section 29 Notice Holders Details – North Valiant PD	13
Table 1.4.4: Pipelines Being Decommissioned	13
Table 1.4.5: Pipeline Section 29 Notice Holders Details – LOGGS Pipelines	13
Table 1.4.8: Pipeline Riser Section 29 Notice Holders Details – Anglia (PL854 & PL855)	14
Table 1.4.6: Pipeline Riser Section 29 Notice Holders Details – Ann (PL947)	14
Table 1.4.7: Pipeline Riser Section 29 Notice Holders Details – Clipper South (PL2810 & PL2811)	14
Table 1.5.1: Summary of Decommissioning Programmes	15
Table 1.6.1: List of Adjacent Facilities	18
Table 2.1.1: Surface Facilities Information	23
Table 2.2.1: Pipeline / Flowline / Umbilical Information	29
Table 2.3.1: Riser Information	30
Table 2.3.2: Pipeline Crossing Information	31
Table 2.3.3: Subsea Structures and Stabilisation Features	39
Table 2.3.4: Subsea Pipeline Stabilisation Features	39
Table 2.4.1: Well Information	41
Table 3.1.1: Cleaning of Topsides for Removal	46
Table 3.1.2: Topsides Removal Methods	47

Table 3.2.1: Jacket Removal Methods	55
Table 3.3.1: Pipeline or Pipeline Groups / Decommissioning Options	56
Table 3.3.2: Outcomes of Comparative Assessment	56
Table 3.4.1: Subsea Pipeline Protection Structures & Stabilisation Features	57
Table 3.5.1: Pipeline Protection & Stabilisation Features	58
Table 3.6.1: Well Decommissioning	59
Table 3.7.1: Waste Stream Management Method	59
Table 3.7.2: Waste Stream Management Methods	59
Table 4.1.1: Environmental Impact Management	60
Table 4.2.1: Environmental Impact Management	64
Table 4.2.1: Summary of Stakeholder Comments	67

TABLE OF TERMS AND ABBREVIATIONS

Abbreviation	Explanation
approaches	Refer to pipelines as they come nearer to the risers on the installations
Branch Tee	Section of pipeline furnished with additional valves and pipework to allow for future expansion, a protection structure and protection and stabilisation features such as mattresses and deposited rock
CA	Comparative Assessment (Report)
CCUS	Carbon Capture Usage and Storage
Chrysaor	Chrysaor Production (UK) Limited
CMS	Caister Murdoch System
CSV	Construction Support Vessel
CTE	Coal Tar Enamel (pipeline coating)
Cut and lift	The 'cut and lift' method of removing trenched and buried pipelines would involve excavating the pipelines from within the seabed and thereafter cutting the pipeline into recoverable and transportable lengths. This method of removal can be very time-consuming for long pipelines and, would be problematic for concrete coated pipelines. The method is usually only viable for short pipelines
CWC	Concrete Weight Coated
DCA	Decommissioning Operations Application
DP	Decommissioning Programme
EA	Environmental Appraisal
EMS	Environmental Management System
ESDV	Emergency Shutdown Valve
FBE	Fusion Bonded Epoxy
FPAL	First Point Assessment Limited (UK)
Full removal	The full removal options for decommissioning the pipelines would involve using the 'cut and lift' method of removal especially for the larger pipeline and the presence of concrete weight coating and piggyback clamps on the platform approaches
GMG	Global Marine Group
HAT	Highest Astronomical Tide
HLV	Heavy Lift Vessel
HSE	Health & Safety Executive
Ineos	INEOS UK SNS Limited
Ithaca	Ithaca Energy (UK) Limited
JUWB	Jack Up Work Barge
kg	kilogram
km	kilometre
KP	Kilometre Point, usually measured from point of origin, the start of the pipeline
LAT	Lowest Astronomical Tide
LDPE	Low Density Polyethylene
Leave <i>in situ</i>	Leave <i>in situ</i> for pipelines would involve leaving trenched and buried pipelines <i>in situ</i> and risk assessing any exposures and spans
LOGGS Installation	The LOGGS Installation comprises LOGGS PA, PC, PP, PR and North Valiant PD. All installations are bridge linked.
LOGGS PA	LOGGS PA Accommodation Platform
LOGGS PC	LOGGS PC Compression Platform
LOGGS PP	LOGGS PP Processing Platform
LOGGS PR	LOGGS PR Riser Platform
LOGGS	Lincolnshire Offshore Gas Gathering System
m	metres
MAT, SAT	Master Application Template, Supplementary Application Template
MCV	Multipurpose Construction Vessel
MCZ	Marine Conservation Zone
MEG	Monoethylene Glycol
MeOH	Methanol
MLWM	Mean Low Water Mark (1.548km to 'Sphere Receiver' at TGT)

Abbreviation	Explanation
n/a	Not Applicable
N,S,E,W	North, South East & West
North Valiant PD	North Valiant (1) PD Platform, bridge linked to LOGGS PP
North Valiant SP	Second North Valiant (2) installation comprising small topsides and jacket held in location using 4x piles
NFFO	National Federation of Fishermen's Organisations
NIFPO	Northern Ireland Fish Producers Organisation
NORM	Naturally Occurring Radioactive Material
NUI	Normally Unattended Installation
OGA	Oil and Gas Authority
OGUK	Oil and Gas United Kingdom
OPRED	Offshore Petroleum Regulator for Environment and Decommissioning
OSPAR	Oslo-Paris Convention
Partial removal	The partial removal decommissioning option for pipelines would involve excavating trenched and buried pipelines local to the exposed ends of the pipeline and thereafter effecting removal of the section of pipeline using the 'cut and lift' method. Typically, the excavated locations and cut pipeline ends in the seabed may need to be remediated in some way, either by back-filling the excavated material or by depositing rock
Perenco	Perenco UK Limited
Pipeline Crossing	A pipeline with a higher identification number crosses over the top of a pipeline with a lower identification number. Typically, pipeline crossings might be protected with concrete mattresses and overlain with deposited rock
PL	Pipeline identification numbers
Platform	Installation, typically comprising topsides and jacket
PON	Petroleum Operations Notice
PWA	Pipeline Works Authorisation
Riser	Pipe that connects the pipeline to the topsides' pipework
SAC	Special Areas of Conservation
SAT	Subsidiary Application Template
SFF	Scottish Fishermen's Federation
Shell	Shell U.K. Limited
SLV	Shear Leg Vessel
SNS	Southern North Sea
SPA	Special Protection Area
Spirit Energy	Spirit Energy North Sea Limited
South Valiant TD	Installation comprising small topsides and jacket held in location using 4x piles
SSCV	Semi-Submersible Crane Vessel
Te	Tonne(s)
TGT	Theddlethorpe Gas Terminal (WGS84 Degrees: 53.362438° N .237783° E)
UK	United Kingdom
UKCS	United Kingdom Continental Shelf
UTM	Universal Transverse Mercator (Coordinate System)
V fields	Collectively along with the Vulcan (2) UR installation, Vanguard QD, North Valiant (2) SP, South Valiant TD & Vulcan (1) RD are known as the V fields satellites
Vanguard QD	Installation comprising small topsides and jacket held in location using 4x piles
Vulcan RD	First Vulcan (1) installation comprising small topsides and jacket held in location using 4x piles
Vulcan UR	Second Vulcan (2) installation comprising small topsides and jacket held in location using 4x piles
WGS84	World Geodetic System 84 is the reference coordinate system used by the Global Positioning System
x	Number of (e.g. 16x = 16 in Number)

1 Executive Summary

1.1 Combined Decommissioning Programmes

This document contains three Decommissioning Programmes, one for each set of notices under Section 29 of the Petroleum Act 1998. The Decommissioning Programmes are:

- LOGGS PR, LOGGS PC, LOGGS PP, LOGGS PA Installations;
- North Valiant (1) PD installation;
- The pipelines associated with LOGGS PP, PL454 and PL455.

Collectively the LOGGS PR, LOGGS PC, LOGGS PP, LOGGS PA and North Valiant (1) PD installations are known as the LOGGS Installation. The North Valiant PD installation is linked to LOGGS PP by bridge. Although decommissioning of these installations and pipelines is being treated in this document as a standalone project, the operational phase is being carried out as part of a wider decommissioning campaign in the LOGGS area. Chrysaor Production (U.K.) Limited (Chrysaor) shall also continue to explore cost saving synergies with other projects.

1.2 Requirement for Decommissioning Programmes

Installations: In accordance with the Petroleum Act 1998, Chrysaor, as operator of the LOGGS Installation, and on behalf of the Section 29 notice holders (Table 1.4.2, Table 1.4.3), is applying to the Offshore Petroleum Regulator for Environment and Decommissioning (OPRED) to obtain approval for decommissioning the installations detailed in Section 2 of this document. Two partner Letters of Support will be added to the Decommissioning Programme following statutory consultation.

Pipelines: In accordance with the Petroleum Act 1998, Chrysaor, as operator of the LOGGS PP pipelines, and on behalf of the Section 29 notice holders (Table 1.4.5, and Table 1.4.7), is applying to OPRED to obtain approval for decommissioning the pipelines detailed in Section 2 of this document. Two partner Letters of Support will be added to the Decommissioning Programme following statutory consultation.

In conjunction with public, stakeholder and regulatory consultation, the Decommissioning Programmes are submitted in compliance with national and international regulations and OPRED guidance notes. Partner Letters of Support will be provided directly to OPRED. The schedule outlined in this document is for a decommissioning project which commenced with the pipeline flushing and platform removal preparation from an Accommodation Work Vessel in 2018. Well decommissioning also commenced in 2018 and decommissioning of the facilities will continue for a further 8 years till completion.

1.3 Introduction

1.3.1 Overview of LOGGS

Chrysaor's Lincolnshire Offshore Gas Gathering System (LOGGS) development consists of a single 'gas gathering' complex which collected gas from a total of 16 'satellite' platforms and 6 subsea centres up to ~55km from the main LOGGS installation.

The initial development of LOGGS Installation consisted of an Accommodation Platform, Production Platform and North Valiant PD wellhead platform and was brought on-stream in 1988. Further developments included installation of a Compression Platform (1988) for transportation of gas to the shore Terminal and a Riser Platform (1993) to accommodate additional small developments from the subsea Ann wellhead, the Ganymede platform, the Callisto subsea development and later with Europa, Vampire, Viking, Viscount, Saturn, Mimas, Tethys, NW Bell and Clipper South. Following the installation of the Clipper South riser in 2011, all six of the installed riser slots on LOGGS PR were used.

The LOGGS Installation comprises of the following 5 jackets which are linked together by fixed bridges:

- PR (Riser Platform);
- PC (Compression Platform);
- PP (Production Platform);

- PA (Accommodation Platform);
- PD (North Valiant 1 Wellhead Platform).

LOGGS comprises a central complex, known as the LOGGS Installation, and user fields which export to the installation. The products were exported from the LOGGS Installation via PL454, a 36" concrete coated trunkline to the Theddlethorpe Gas Terminal. Methanol and chemicals used to be imported at LOGGS PP from Theddlethorpe via PL455, a 4" pipeline.

The V fields and Satellite installations and associated pipelines are addressed in Decommissioning Programmes submitted separately [1],[2].

LOGGS PR and LOGGS PP act as hosts to several third-party pipelines. These are presented in Figure 1.3.1.

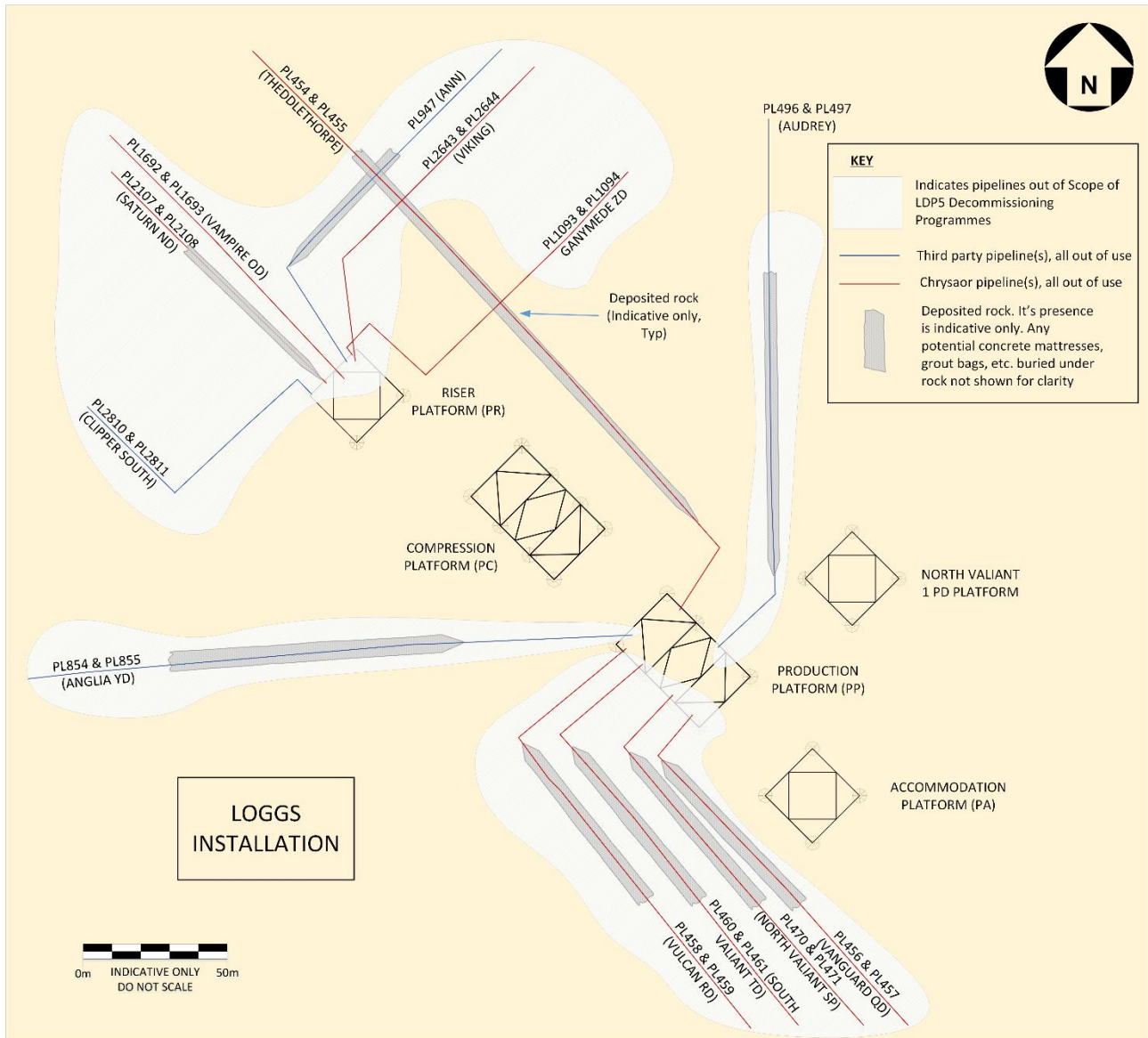

Figure 1.3.1: LOGGS Installation – Pipelines

The application for Cessation of Production of the North Valiant field – which includes North Valiant PD and SP, was approved by OGA in September 2016, as the field was uneconomic. Production through LOGGS ceased in October 2018 as part of an area-wide decision to shut in CMS, LOGGS and TGT. Cessation at LOGGS was also linked to the timing of hydrocarbons from the largest producer – Clipper South, being diverted away from LOGGS. Once the production from Clipper South was diverted it became uneconomic for the remaining fields to export via LOGGS.

North Valiant PD ceased production in 2016. Noting that the LOGGS installation acted as a hub, further field life extension options were investigated for the LOGGS installation but by the time production was ceased

(2018), these, along with other reuse options of the facilities and they were deemed not feasible. Chrysaor is aware that pipeline PL454 has been flagged as having potential for re-use for CCUS projects and have undertaken discussions with the OGA. The current proposed decommissioning option for PL454 does not preclude the potential for reuse in the future.

1.3.2 LOGGS PR

LOGGS PR acts as host to the following pipelines. Where available, the relevant Decommissioning Programmes are italicised in parentheses, together with the date if they have already been approved by the Secretary of State:

- PL947 12" Gas Export Ann XM to LOGGS PR ~41.8km long (*Ann and Alison*, April 2018);
- PL1093 18" Gas Export Ganymede ZD to LOGGS PR ~19.1km long (*LOGGS Satellites LDP3*, May 2020);
- PL1094 3" MeOH LOGGS PR to Ganymede ZD ~19.1km long (*LOGGS Satellites LDP3*, May 2020)
- PL1692 12" Gas Export Vampire OD to LOGGS PR ~9.2km long, (*LOGGS Satellites (LDP1)*, November 2017);
- PL1693 3" MeOH LOGGS PR to Vampire OD ~9.2km long (*LOGGS Satellites (LDP1)*, November 2017);
- PL2107 14" Gas Export Saturn ND to LOGGS PR ~43.2km long;
- PL2108 3" MeOH LOGGS PR to Saturn ND ~43.2km long;
- PL2643 16" Gas Export Viking to LOGGS PR ~19.1km long (*Viking (VDP2)*, January 2019);
- PL2644 3" MeOH LOGGS PR to Viking ~19.1km long (*Viking (VDP2)*, January 2019);
- PL2810 12" Gas Export Clipper South to LOGGS PR ~15.1km long;
- PL2811 3" MeOH LOGGS PR to Clipper South ~15.1km long.

All these pipelines are out of use and have been flushed, cleaned, and filled with seawater and they are outside the scope of the LDP5 LOGGS Decommissioning Programmes although the Ann and Clipper South risers remain in scope.

1.3.3 LOGGS PC

LOGGS PC has no subsea infrastructure associated with the installation.

1.3.4 LOGGS PP

As well as being the hub for PL454 and PL455, LOGGS PP acts as host to several pipelines. All these pipelines are out of use and have been flushed, cleaned, and filled with seawater.

The decommissioning of the following eight pipelines is addressed in the LDP4 LOGGS V fields Decommissioning Programmes [1].¹

- PL456 10" Vanguard QD to LOGGS PP ~7.5km long;
- PL457 3" MeOH LOGGS PP to Vanguard QD ~7.5km long;
- PL458 18" Vulcan RD to LOGGS PP ~16.0km long;
- PL459 3" MeOH LOGGS PP to Vulcan RD ~16.0km long;
- PL460 10" South Valiant TD to LOGGS PP ~10.6km long;
- PL461 3" MeOH LOGGS PP to South Valiant TD ~10.6km long;
- PL470 10" North Valiant SP to LOGGS PP ~4.3km long;
- PL471 3" MeOH LOGGS PP to North Valiant SP ~4.3km long;

The decommissioning of the following third-party pipelines is also outside the scope of the LDP5 LOGGS Decommissioning Programmes and addressed elsewhere, although the Anglia risers remain in scope. Where available, the relevant Decommissioning Programmes are italicised in parentheses, together with the date if they have already been approved by the Secretary of State.

¹ The Decommissioning Programmes for LDP4 has been prepared and is currently being reviewed before being issued for statutory consultation. These Decommissioning Programmes address the decommissioning of the Vanguard QD, North Valiant SP, South Valiant TD and Vulcan RD and associated pipelines.

- PL496 20" Gas Export Audrey A (WD) to LOGGS PP ~16.5km long (*Audrey*, April 2018)
- PL497 3" MeOH LOGGS PP to Audrey A (WD) ~16.5km long (*Audrey*, April 2018);
- PL854 12" Gas Export Anglia YD to LOGGS PP ~23.6km long (*Anglia*, June 2020);
- PL855 3" MeOH LOGGS PP to Anglia YD ~23.6km long (*Anglia*, June 2020).

1.3.5 LOGGS PA

LOGGS PA has no subsea infrastructure associated with the installation.

1.3.6 North Valiant PD

The North Valiant field was discovered in 1970 and lies within the main Southern North Sea (SNS) Gas Province in UK Blocks 49/16. The field lies ~119km East South East from the Theddlethorpe Gas Terminal and ~69km North East of the North Norfolk coast in water depths between 21.9m and 28.3m.

It was developed using two installations, the North Valiant (1) PD and North Valiant (2) SP. The field achieved first production in 1988. Both installations are normally unattended installations (NUIs) supported by conventional four-legged piled wellhead steel jackets. Gas from the North Valiant SP installation used to be exported to LOGGS PP via PL470, an 18" concrete coated pipeline. This pipeline is piggybacked by PL471, a 3" pipeline that used to supply methanol and chemicals from LOGGS PP. The Cessation of Production justification for North Valiant PD was approved by the Oil and Gas Authority on 20 Sept 2016.

The North Valiant (2) SP installation and associated pipelines are addressed in Decommissioning Programmes submitted separately [1].

1.3.7 Submission of Decommissioning Programmes

Following public, stakeholder and regulatory consultation, the Decommissioning Programmes will be submitted without derogation and in full compliance with the OPRED guidance notes [9]. The Decommissioning Programmes explain the principles of the removal activities and are supported by an environmental appraisal [3]. The Decommissioning Programmes for the pipelines are also supported by a comparative assessment [4].

1.4 Decommissioning Overview

1.4.1 Installations

Table 1.4.1 Installations Being Decommissioned										
Field Names		Quad / Block		Surface Installations					Distances	
Fields	Water Depth	Type of Production	UKCS Block(s)	Number	Function	Type	Topsides Weight (Te)	Jacket Weight (Te) ²	Distance to Median (Netherlands)	Distance from nearest UK coastline
LOGGS PR	~21.0m	Gas, Condensate	49/16	1	Riser Platform	Steel Jacket (4-Legs)	2,499	1,870	~65km	~68.8km
LOGGS PC	~21.0m	Gas, Condensate	49/16	1	Compression Platform	Steel Jacket (8-Legs)	4,752	2,109	~65km	~68.8km
LOGGS PP	~21.0m	Gas, Condensate	49/16	1	Processing Platform	Steel Jacket (8-Legs)	3,950	2,347	~65km	~68.8km
LOGGS PA	~21.0m	n/a	49/16	1	Accommodation Platform	Steel Jacket (4-Legs)	2,418	1,444	~65km	~68.8km
North Valiant PD	~21.0m	Gas, Condensate	49/16	1	Wellhead Platform	Wellhead Steel Jacket (4 Legs)	602	1,324	~65km	~68.8km
Drill Cuttings				Subsea Installations				Number of Wells		
Field	Drill Cuttings Pile(s)	Total Estimated Volume (m ³)	Number		Type		Platform	Subsea		
LOGGS PR, PC, PP & PA	n/a	n/a	n/a		n/a		n/a	n/a		
North Valiant PD	n/a	n/a	n/a		n/a		7	n/a		

² Includes weight of piles

Table 1.4.2: Installation Section 29 Notice Holders Details – LOGGS PR, PC, PP & PA

Section 29 Notice Holders	Registration Number	Equity Interest
Chrysaor Production (U.K.) Limited (Operator)	00524868	20%
Chrysaor Petroleum Limited	01247477	30%
BP Exploration (Alpha) Limited	01021007	30%
BP Exploration Beta Limited	00895797	20%
BP Exploration Operating Company Limited	00305943	0%
BP Exploration Services Limited	00777236	0%

Table 1.4.3: Installation Section 29 Notice Holders Details – North Valiant PD

Section 29 Notice Holders	Registration Number	Equity Interest
Chrysaor Production (U.K.) Limited (Operator)	00524868	0%
Chrysaor Developments Limited	02180666	61.134%
BP Exploration (Alpha) Limited	01021007	38.866%
Britoil Limited	SC077750	0%

1.4.2 Pipelines

Table 1.4.4: Pipelines Being Decommissioned

Field	Number of Pipelines	
LOGGS (PP)	2	Refer Table 2.2.1

Table 1.4.5: Pipeline Section 29 Notice Holders Details – LOGGS Pipelines

Section 29 Notice Holders	Registration Number	Equity Interest
Chrysaor Production (U.K.) Limited (Operator)	00524868	20%
Chrysaor Petroleum Limited	01247477	30%
BP Exploration (Alpha) Limited	01021007	30%
BP Exploration Beta Limited	00895797	20%
BP Exploration Operating Company Limited	00305943	0%
BP Exploration Services limited	00777236	0%

1.4.3 Risers

The original third-party ownership of the risers has transferred to the owners of the LOGGS PR and LOGGS PP installations. This section has been added to document this.

Table 1.4.6: Pipeline Riser Section 29 Notice Holders Details – Anglia (PL854 & PL855)

Section 29 Notice Holders	Registration Number	Equity Interest
Chrysaor Production (U.K.) Limited (Operator)	00524868	20%
Chrysaor Petroleum Company U.K. Limited	00792712	30%
BP Exploration (Alpha) Limited	01021007	30%
BP Exploration Beta Limited	00895797	20%
Neptune E&P UKCS Limited	03386464	0%
Ithaca Energy Limited	JE126983	0%
Ithaca Energy (UK) Limited	SC272009	0%
INEOS UK SNS Limited	01021338	0%
INEOS UK E&P Holdings Limited	SC200459	0%
Dana Petroleum Limited	03456891	0%
Dana Petroleum (E&P) Limited	02294746	0%

Table 1.4.7: Pipeline Riser Section 29 Notice Holders Details – Ann (PL947)

Section 29 Notice Holders	Registration Number	Equity Interest
Chrysaor Production (U.K.) Limited (Operator)	00524868	100%

Table 1.4.8: Pipeline Riser Section 29 Notice Holders Details – Clipper South (PL2810 & PL2811)

Section 29 Notice Holders	Registration Number	Equity Interest
Chrysaor Production (U.K.) Limited (Operator)	00524868	20%
Chrysaor Petroleum Company U.K. Limited	00792712	30%
BP Exploration (Alpha) Limited	01021007	30%
BP Exploration Beta Limited	00895797	20%

1.5 Summary of Proposed Decommissioning Programmes

Table 1.5.1: Summary of Decommissioning Programmes	
Proposed Decommissioning Solution	Reason for Selection
1. Topsides (LOGGS PR, PC, PP, PA and North Valiant PD)	
Complete removal and recycling. The topsides will be removed and recovered to shore and recycled. Environmental permit applications required for work associated with removal of the topsides will be applied for.	Allows jacket to be removed and maximises recycling of materials.
2. Jackets (LOGGS PR, PC, PP, PA and North Valiant PD)	
Complete removal and recycling. The leg piles will be cut 3.0m below seabed and the jacket, along with all the risers will be removed and recovered to shore for recycling. Environmental permit applications required for work associated with removal of the jacket will be applied for.	To comply with OSPAR requirements leaving unobstructed seabed. Removes a potential obstruction to fishing operations and maximises recycling of materials.
3. Pipelines (LOGGS PP only)	
<p>PL454 & PL455 have been flushed and will be left buried <i>in situ</i>.</p> <p>On approach to the LOGGS PP installation the exposed pipeline ends will be cut where they enter or exit the deposited rock and removed (~25m long). Up to 25Te of rock will be deposited to bury the cut pipeline ends.</p> <p>If exposed, 1Te grout bags supporting the pipelines will be removed. Other pipeline stabilisation materials such as scour protection concrete mattresses and any grout bags between them will be left <i>in situ</i>.</p> <p>Any permit applications required for work associated with cutting and removal will be submitted.</p>	<p>Outside the 500m safety zones the pipelines will already have been exposed to fishing activity.</p> <p>The comparative assessment recommends that the pipelines be left <i>in situ</i>. The pipelines are sufficiently buried and stable but suffers from exposures along 24% of its length. PL454 has one reportable span near the PL2810 12" Clipper South RL gas export & PL2811 3" MeOH pipeline crossing, ~20m long.</p> <p>Minimal seabed disturbance, lower energy usage, reduced risk to personnel engaged in the activity.</p> <p>Reduces the requirement for the introduction of new material such as deposited rock to the North Norfolk Sandbanks and Saturn Reef Special Area of Conservation (SAC).</p> <p>Monitoring to confirm the pipelines remain buried will be completed to a schedule agreed with OPRED.</p> <p>Given the mobile nature of the seabed the reportable span at the Clipper pipeline crossing in the meantime will be monitored but not remediated.</p>
4. Risers	
All risers will be completely removed along with the LOGGS PP and PR jackets.	To comply with OSPAR requirements leaving unobstructed seabed. Removes a potential obstruction to fishing operations and maximises recycling of materials.
5. Well Decommissioning (North Valiant PD only)	
All wells have been decommissioned in accordance with the version of Oil & Gas UK Well Decommissioning Guidelines relevant at the time and to comply with HSE "Offshore Installations and Wells (Design and Construction, etc.) Regulations 1996".	Meets the OGA and HSE regulatory requirements.
6. Drill Cuttings (North Valiant PD only)	
None required.	No drill cuttings piles have been identified by seabed survey.

Table 1.5.1: Summary of Decommissioning Programmes	
Proposed Decommissioning Solution	Reason for Selection
7. Interdependencies	
<p>The whole of the five installations will be removed. The piles will be cut with seabed sediment being displaced to allow access for cutting.</p> <p>No third-party pipeline crossings will be disturbed as a result of the decommissioning proposals.</p> <p>Any concrete mattresses and grout bags that are removed to gain access to infrastructure will be removed. Those that are not exposed will remain <i>in situ</i> and not be disturbed. Deposited rock will remain <i>in situ</i>.</p>	

1.6 Field Location including Field Layout and Adjacent Facilities

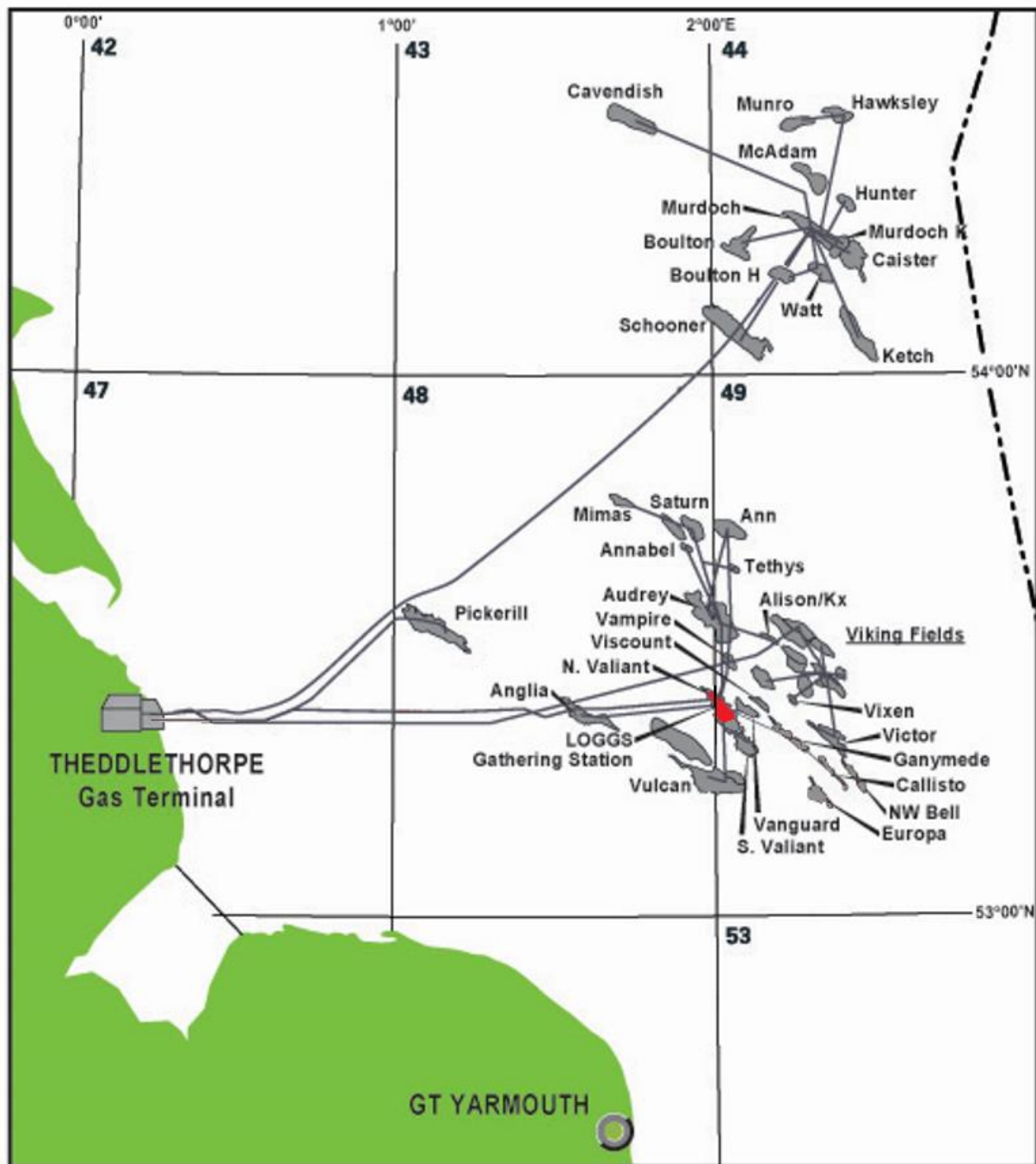

Figure 1.6.1: LOGGS Installation Location in UKCS

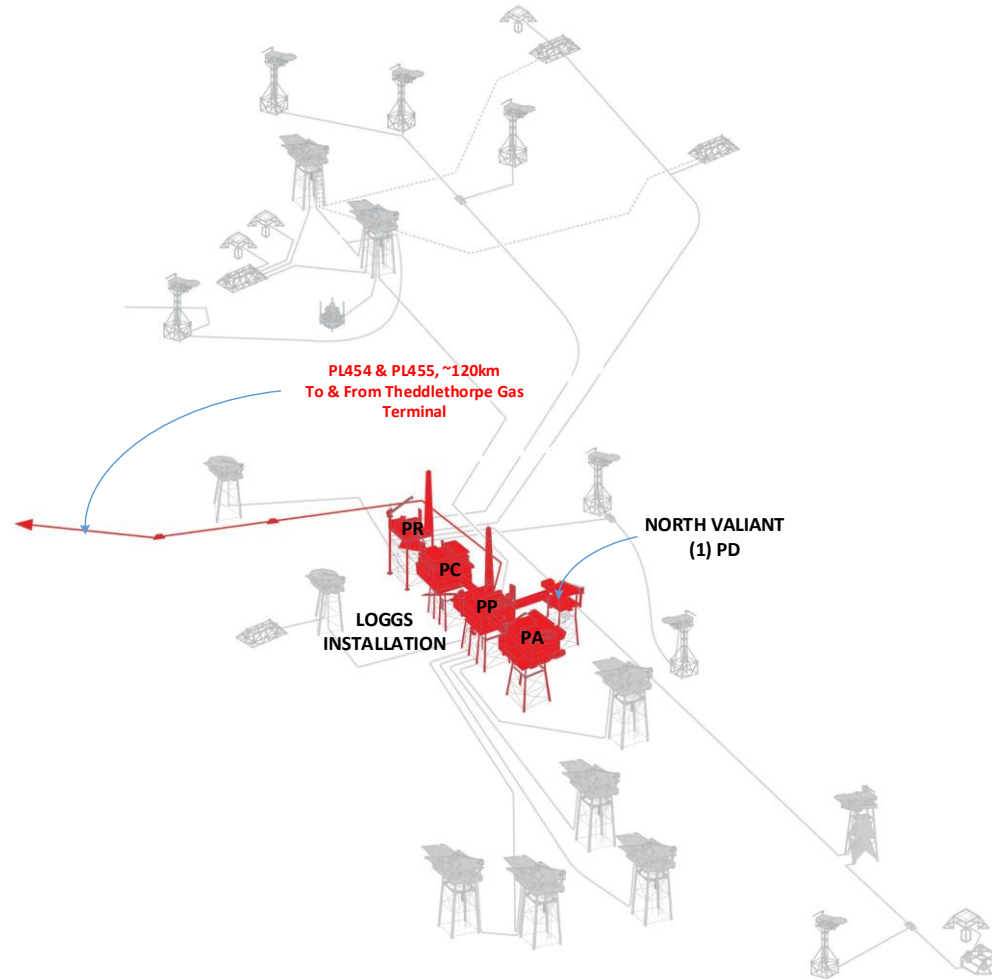

Figure 1.6.2: LOGGS Installation Layout

Table 1.6.1: List of Adjacent Facilities

Owner	Name	Type	Direction & Distance from LOGGS PP	Information	Status
Chrysaor	Vanguard QD	Fixed Steel Wellhead Platform	E, 7.2km	Refer DP for LDP4 [1]	Out of use
Ineos UK SNS	Clipper South Platform	Fixed Steel Platform	W, 14.7km		Operational
Shell	Skiff Platform	Fixed Steel Platform	NWW, 10.3km		Operational
Shell	Galleon PN	Fixed Steel Platform	NW, 11.3km		Operational
Chrysaor	Vampire OD	Fixed Steel Wellhead Platform	N, 8.8km	DP (LDP1) approved Nov 2017; removal of installation expected in 2020	Out of use
Chrysaor	South Valiant TD	Fixed Steel Wellhead Platform	SE, 10km	Refer DP for LDP4 [1]	Out of use
Chrysaor	North Valiant (2) SP	Fixed Steel Wellhead Platform	SE, 4.3km	Refer DP for LDP4 [1]	Out of use
Chrysaor	Viscount VO	Fixed Steel Satellite Platform	E, 9.6km	DP (LDP1) approved Nov 2017	Out of use
Chrysaor	Vixen VM	Subsea Wellhead	NEE, 15.2km	DP (VDP2) approved Jan 2019	Out of use
Chrysaor	Victor JM North West	Subsea Wellhead	E, 19.7km	DP (VDP3) approved Jan 2019	Out of use
Chrysaor	Victor JD Valve Skid	Valve Skid	E, 24.7km	DP (VDP3) approved Jan 2019	Out of use
Chrysaor	Viking Bravo	Fixed Steel Accommodation, Compression, Production & Drilling Platforms	NEE, 22.6km	DP (VDP2) approved Jan 2019; removal of installation expected in 2020	Out of use
Chrysaor	Victoria SM Valve Skid	Victoria Valve Skid	E, 24.7km	DP (VDP2) approved Jan 2019	Out of use
Ithaca	Anglia A & Anglia West B	Fixed Wellhead Steel Platform & Subsea Manifold	WSW, 23.5km	DP Approved June 2020	Out of use
Chrysaor	Vulcan (1) RD	Fixed Steel Wellhead Platform	SSE, 15.9km	Refer DP for LDP4 [1]	Out of use
Chrysaor	PL1093 18" Ganymede ZD gas export & PL1094 3" MeOH supply pipelines	Pipeline Crossing over PL454 & PL455	SW, 0.2km	Within LOGGS Installation 500m zone	Out of use
Chrysaor	PL2643 16" Viking BP gas export & PL2644 3" MeOH pipelines	Pipeline crossing over PL454 & PL455	WSW, 0.2km	Within LOGGS Installation 500m zone	Out of use
Spirit Energy	PL496 20" gas export pipeline & PL497 3" MeOH Pipeline	Pipeline crossing over PL454 & PL455	WSW, 0.2km	Audrey DP approved April 2018; Within LOGGS' 500m zone	Out of use
Chrysaor	PL1692 12" Vampire OD gas export & PL1693 3" MeOH	Pipeline crossing over PL454 & PL455	WSW, 0.2km	Within LOGGS' 500m zone	Operational

Table 1.6.1: List of Adjacent Facilities					
Owner	Name	Type	Direction & Distance from LOGGS PP	Information	Status
	pipelines				
Chrysaor	PL2107 14" Saturn ND gas export & PL2108 3" MeOH pipelines	Pipeline crossing over PL454 & PL455	WSW, 0.2km	Within LOGGS' 500m zone	Out of use
Ineos UK SNS	PL2810 12" Clipper South RL gas export & PL2811 3" MeOH pipelines	Pipeline crossing over PL454 & PL455	NWW, 2.1km		Out of use
Shell	PL632 24" Clipper PT to Bacton (East) gas terminal gas trunkline	Pipeline crossing over PL454 & PL455	WSW, 19.7km		Operational
Shell	PL996 3" Bacton (West) Gas Terminal to Clipper PT MEG pipeline	Pipeline crossing over PL454 & PL455	WSW, 19.6km		Operational
Perenco	PL253 24" Esmond to Bacton gas export pipeline	Pipeline crossing under PL454	WSW, 26.9km	PL454 & PL455 separately cross over PL253	Operational
Chrysaor	PL27 28" Viking AR to Theddlethorpe gas export & PL161 MeOH pipelines	Pipeline crossing under PL454 & PL455	WSW, 38.2km	PL454 & PL455 separately cross over PL27 & PL161	Out of use
Impacts of Decommissioning Proposals					
No impact is expected.					

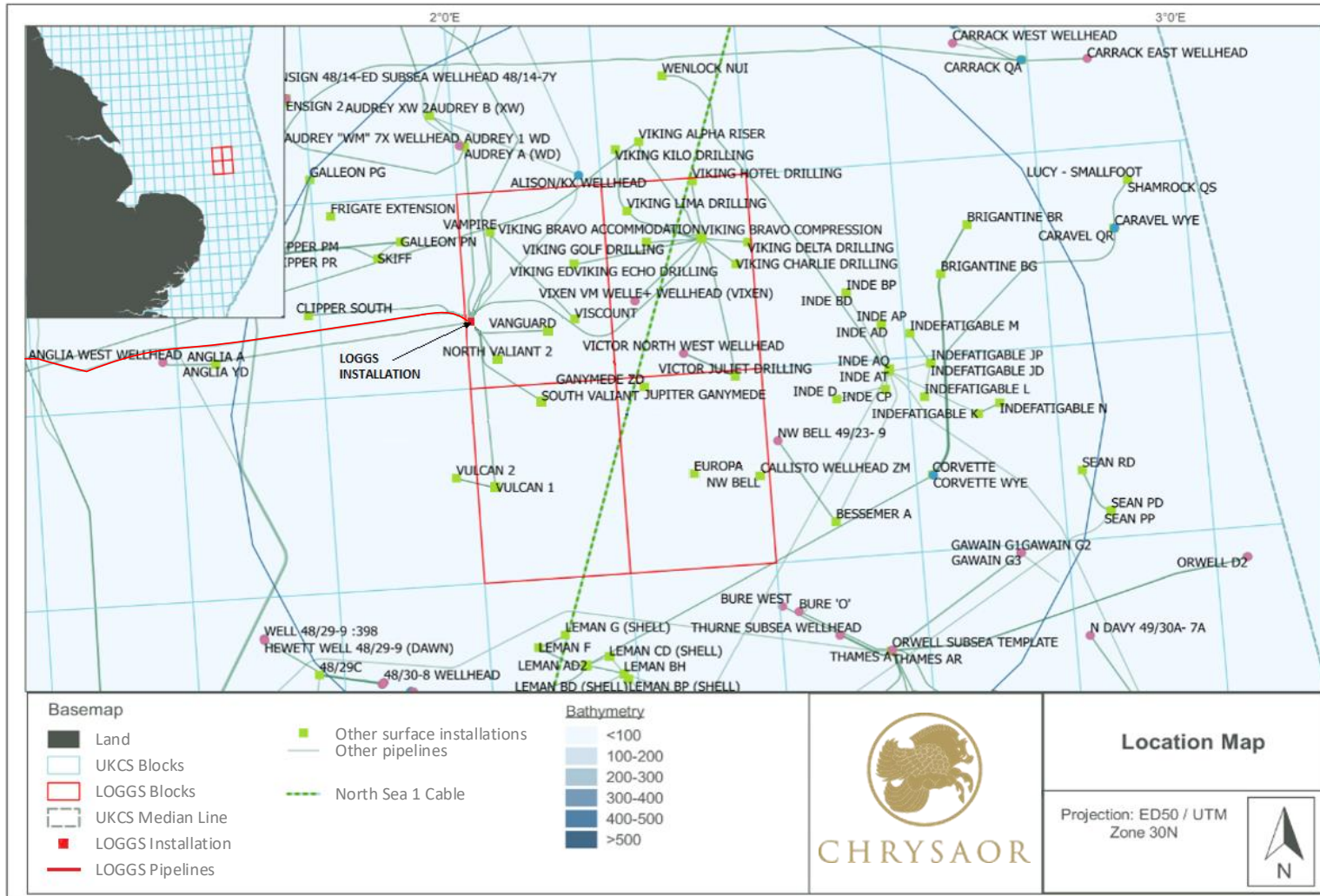

Figure 1.6.3: Adjacent Facilities (LOGGS Installation and pipelines in red)

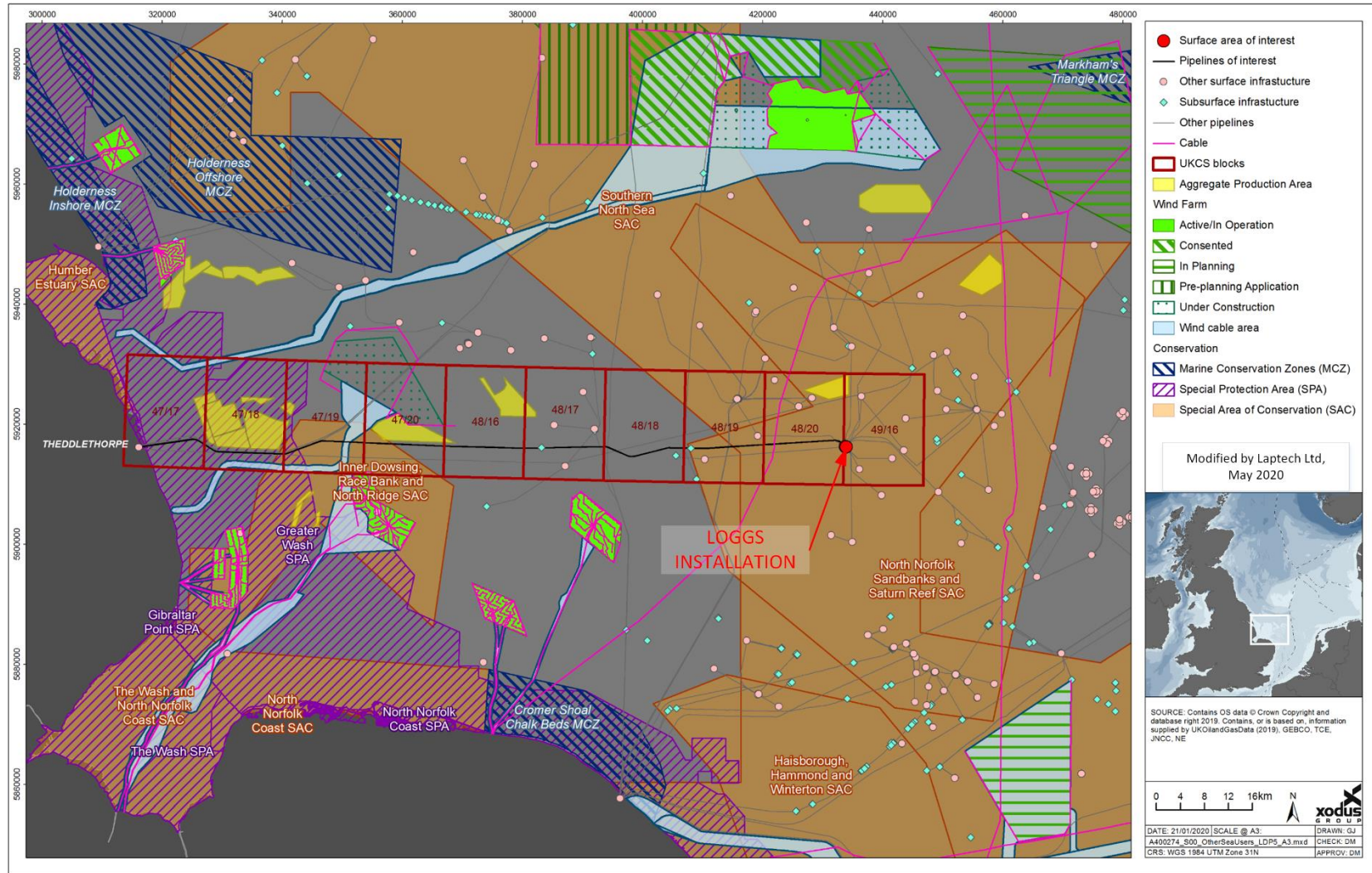

Figure 1.6.4: Adjacent Facilities in relation to non-oil and gas features and infrastructure)

1.7 Industrial Implications

Principles of the contracting and procurement strategies to be utilised by Chrysaor as operator and on behalf of the other Section 29 notice holders, for the decommissioning of the LOGGS Installation (LOGGS PR, LOGGS PC, LOGGS PP, LOGGS PA & North Valiant (1) PD and associated pipelines are listed below:

- 1) Chrysaor participates in the PILOT Share Fair events providing one-to-one sessions with the UK supply chain on the SNS decommissioning programmes and timeline.
- 2) The First Point Assessment (FPAL) database is the primary source for establishing tender lists for contracts or purchases valued at US\$ 100,000 and above, although it is also used under this limit.
- 3) Chrysaor is committed to competitively bidding all its major contracts where possible and practicable. We are supporters of the UK Supply Chain Code of Practice and our performance in this regard has been acknowledged through Excellence Awards from Oil & Gas UK.
- 4) Chrysaor are active participants in various industry initiatives including:
 - a. Oil & Gas UK Supply Chain Forum;
 - b. Inventory sharing initiative (Ampelius);
 - c. OGA Decommissioning Board - Supply Chain sub-group.

2 Description of Items to be Decommissioned

2.1 Surface Facilities (Topsides and Jackets)

Table 2.1.1: Surface Facilities Information							
Name	Facility Type	Location	Topsides / Facilities		Jacket (if applicable)		
		WGS84 Decimal	Weight (Te)	No of modules	Weight (Te) ³	No of Legs, Piles	Weight of piles (Te)
		WGS84 Decimal Minute					
LOGGS PR	Fixed Steel Jacket	53.389983° N 2.002242° E	2,499	1	1,772	4, 4	98
		53° 23.3990' N 02° 0.1345' E					
LOGGS PC	Fixed Steel Jacket	53.389650° N 2.003080° E	4,752	1	1,978	8, 8	131
		53° 23.3790' N 02° 0.1848' E					
LOGGS PP	Fixed Steel Jacket	53.389983° N 2.002242° E	3,950	1	2,216	8, 8	131
		53° 23.3990' N 02° 0.1345' E					
LOGGS PA	Fixed Steel Jacket	53.388842° N 2.004438° E	2,418	1	1,346	4, 4	98
		53° 23.3305' N 02° 0.2663' E					
North Valiant (1) PD	Fixed Steel Wellhead Jacket	53.389488° N 2.004613° E	602	1	1,286	4, 4	39
		53° 23.3693' N 02° 0.2768' E					

³ Jacket weight excluding piles.

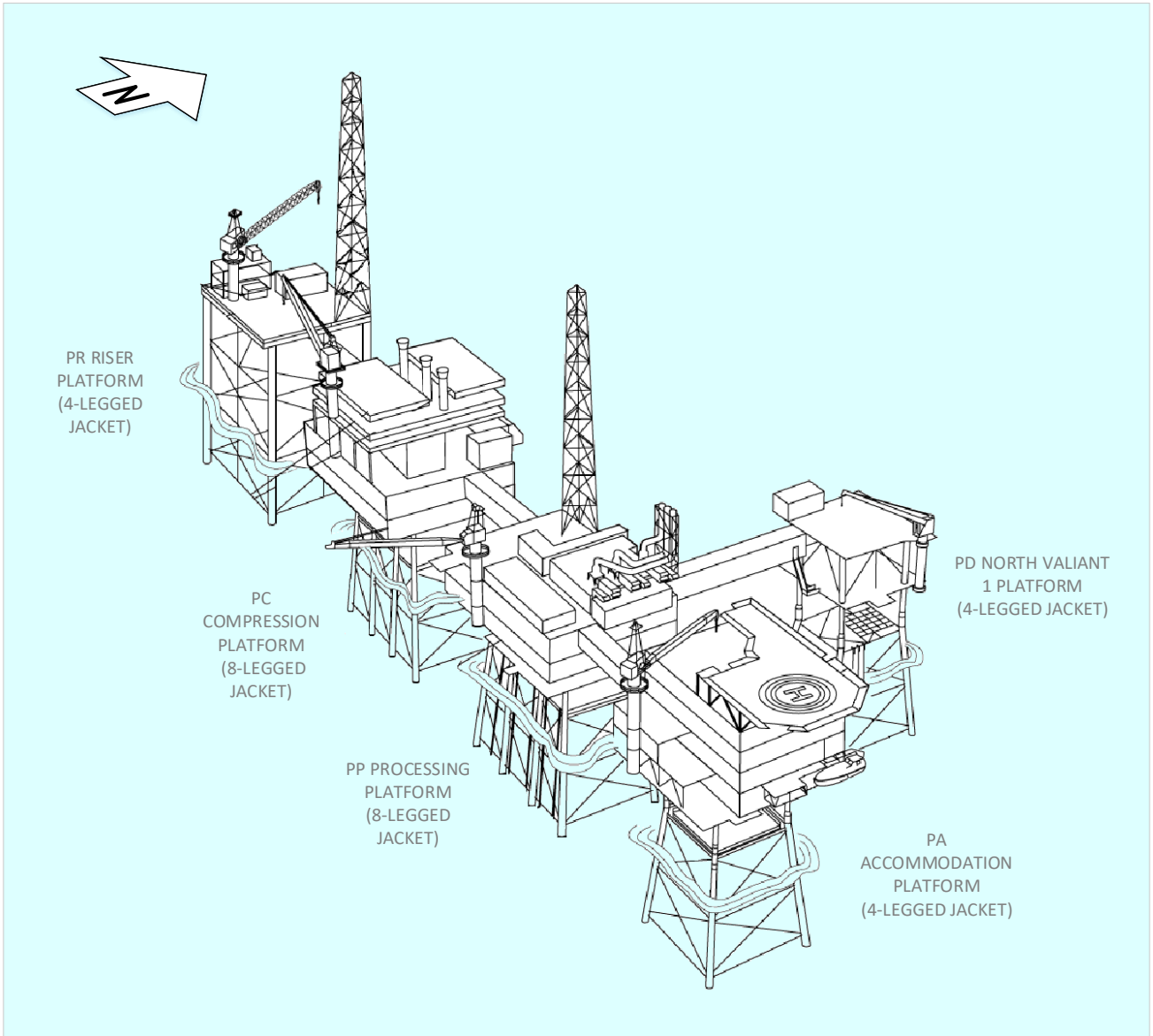

Figure 2.1.1: Illustration Showing the Layout of the LOGGS Installation



Figure 2.1.2: Photograph of the LOGGS Installation, View Looking South-East



Figure 2.1.3: Photograph of the LOGGS Installation, View Looking North



Figure 2.1.4: Photograph of LOGGS PR



Figure 2.1.5: Photograph of LOGGS PC



Figure 2.1.6: Photograph of LOGGS PP



Figure 2.1.7: Photograph of LOGGS PA



Figure 2.1.8: Photograph of North Valiant (1) PD

2.2 Pipelines Including Stabilisation Features

Table 2.2.1: Pipeline / Flowline / Umbilical Information

Description	Pipeline No (as per PWA)	Diameter (inches)	Length (km) ^{2,3}	Description of Component Parts	Product Conveyed	From – To End Points ⁶	Burial Status ¹	Pipeline Status	Current Content
36" Gas Export Pipeline	PL454	36in	118.499	CTE coated steel pipeline coated with CWC for most of its length	Natural gas, condensate, water	Sphere Launcher (LOGGS PP) to MLWM	Trenched and buried with exposures varying in length (total ~28km). There is one reportable span near the PL2810 12" Clipper South RL gas export & PL2811 3" MeOH pipeline crossing., 20m long.	Out of Use	Seawater
3" Methanol import Pipeline	PL455	3in	118.503	FBE resin coated steel pipeline with 50m long polyethylene flexible tie-in spools at LOGGS PP	Methanol and corrosion inhibitor	MLWM to ESDV (LOGGS PP)	Trenched and buried with exposures varying in length (total ~338m)	Out of Use	Seawater

NOTES:

- For further information refer the Comparative Assessment report [4]. For pipeline crossings refer Table 2.3.2;
- PWA variation (356/V/18) quotes 120.047km for PL454. This includes the distance between MLWM and the sphere receiver at TGT;
- PWA variation (356/V/18) quotes 120.051km for PL455. This includes the distance between MLWM and the ESDV at TGT;
- PL455 is piggybacked on PL454 for the first 400m from LOGGS PP and for ~2km from KP116.685 to HAT at KP118.724;
- PL454 incorporates two subsea tees and protection structures at KP26.2 and KP51.5. Refer Figure 2.3.2 and Figure 2.3.3;
- Note that decommissioning of the onshore section of pipelines beyond MLWM is not addressed in this Decommissioning Programme as OPRED has a regulatory remit that only extends as far as MLWM. Regulatory responsibility of the onshore section of pipeline beyond MLWM lies with the Local Planning Authority under the Town and Country Planning Act. At the time of writing, the decommissioning plan for the onshore sections of the pipelines out to the MLWM has not been fully defined, but please refer Appendix 2.

2.3 Risers

Table 2.3.1: Riser Information

Description	Pipeline No (as per PWA)	Diameter (inches)	Length (m)	Description of Component Parts	Product Conveyed	From – To End Points	Burial Status	Pipeline Status	Current Content
12" Gas Export Pipeline Riser	PL947	12	53	Carbon steel	Gas	From Riser tie-in spool weld To & including Loggs ESDV	Exposed (mounted on jacket)	Out of Use	Seawater
12" Gas import pipeline riser	PL854	12	26.75	Carbon steel pipe coated with epoxy	Gas	From riser tie-in spool flange to LOGGS ESDV	Exposed (mounted on jacket)	Out of Use	Seawater
3" MeOH export riser	PL855	3	26.75	Carbon steel pipe coated with epoxy	Methanol and corrosion inhibitor	From riser tie-in spool flange to LOGGS ESDV	Exposed (mounted on jacket)	Out of Use	Seawater
12" Gas export pipeline riser	PL2810	12	28	Carbon steel pipe coated with elastomer and thermal sprayed aluminium	Gas	From LOGGS riser flange to LOGGS Platform ESDV	Exposed (mounted on jacket)	Out of user	Seawater
3" Methanol export pipeline riser	PL2811	3in	28	Carbon steel pipe coated with elastomer and thermal sprayed aluminium	Methanol and corrosion inhibitor	From LOGGS riser flange to LOGGS Platform ESDV	Exposed (mounted on jacket)	Out of Use	Seawater

Table 2.3.2: Pipeline Crossing Information

ID No.	Pipeline Description	KP	Protection
1	PL1093 16" Ganymede ZD to LOGGS PR gas export pipeline and PL1094 3" MeOH pipeline LOGGS PR to Ganymede ZD	~0.15	Within LOGGS' 500m zone. Specific details are not known with certainty. Any protection features such as concrete mattresses & grout bags have been overlain with deposited rock
2	PL496 20" gas export pipeline & PL497 3" MeOH Pipeline	-0.20	
3	PL2643 16" Viking BP to LOGGS PR gas export pipeline & PL2644 3" MeOH pipeline LOGGS PR to Viking BP	~0.20	
4	PL947 12" Ann XM to LOGGS PR gas export pipeline	~0.22	PL454 & piggybacked PL455 trenched and buried. 6 mattresses under PL947, overlain with deposited rock
5	PL1692 12" Vampire OD to LOGGS PR gas export & PL1693 3" MeOH LOGGS PR to Vampire OD pipeline	~0.24	Within LOGGS' 500m zone. Specific details are not known with certainty. Any protection features such as concrete mattresses & grout bags have been overlain with deposited rock
6	PL2107 14" Saturn ND to LOGGS PR gas export & PL2108 3" MeOH LOGGS PR to Saturn ND pipeline	~0.25	
7	PL2810 12" Clipper South RL gas export & PL2811 3" MeOH pipelines	~2.1	Specific details unknown. Any protection features such as concrete mattresses & grout bags have been overlain with deposited rock
8	PL632 24" Gas export trunkline Clipper PT to Bacton (East) Gas Terminal	19.96	
9	PL996 24" gas export trunkline Clipper PT to Bacton (West) Gas Terminal	20.04	
10	PL253 24" Esmond to Bacton gas export pipeline	26.75	Concrete mattresses probably supplemented with grout bags all overlain with deposited rock. Refer Figure 2.3.4
11	PL27 28" Viking AR to TGT gas & PL161 3" MeOH pipeline	38.89	Concrete mattresses probably supplemented with grout bags all overlain with deposited rock. Refer Figure 2.3.5
12	PL1570 34" Shearwater to Bacton (SEAL) pipeline	40.55	Specific details are not known with certainty. Any protection features such as concrete mattresses & grout bags have been overlain with deposited rock
13	PL876 20" Lancelot to Bacton Gas Terminal Gas Trunkline c/w PL877 (HOLD) 3" MEG pipeline	41.86	
14	PL1639 10" Waveney to Lancelot gas export pipeline & PL1640 3" MEG pipeline	~44.0	
NOTES:			
1. A higher PL number crosses over the top of a pipeline with a lower PL number. For example, PL454 & PL455 would be crossing over PL27, PL161 and PL253.			

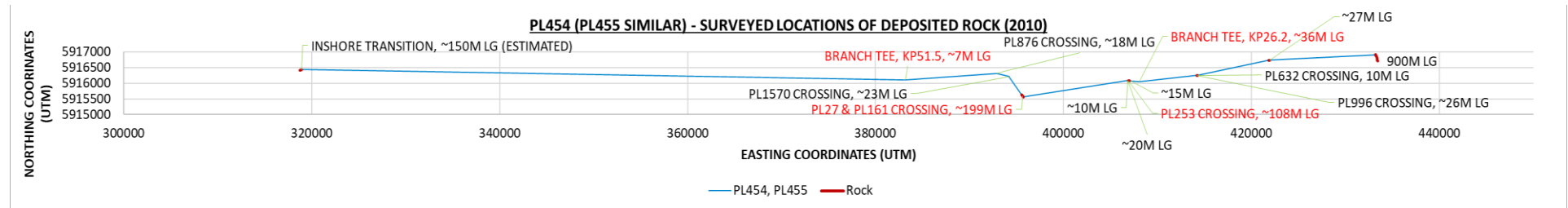

Figure 2.3.1: Pipeline Crossings & Deposited Rock (as surveyed 2010)⁴

⁴ Items in red letters concern rock that was deposited when PL454 and PL455 were installed. Others are concerned with rock that was deposited as protection for third party crossings installed subsequently. Refer Table 2.3.2. The figures that follow, e.g. ‘~199M LG’ refers to the estimated length of rock at the location.

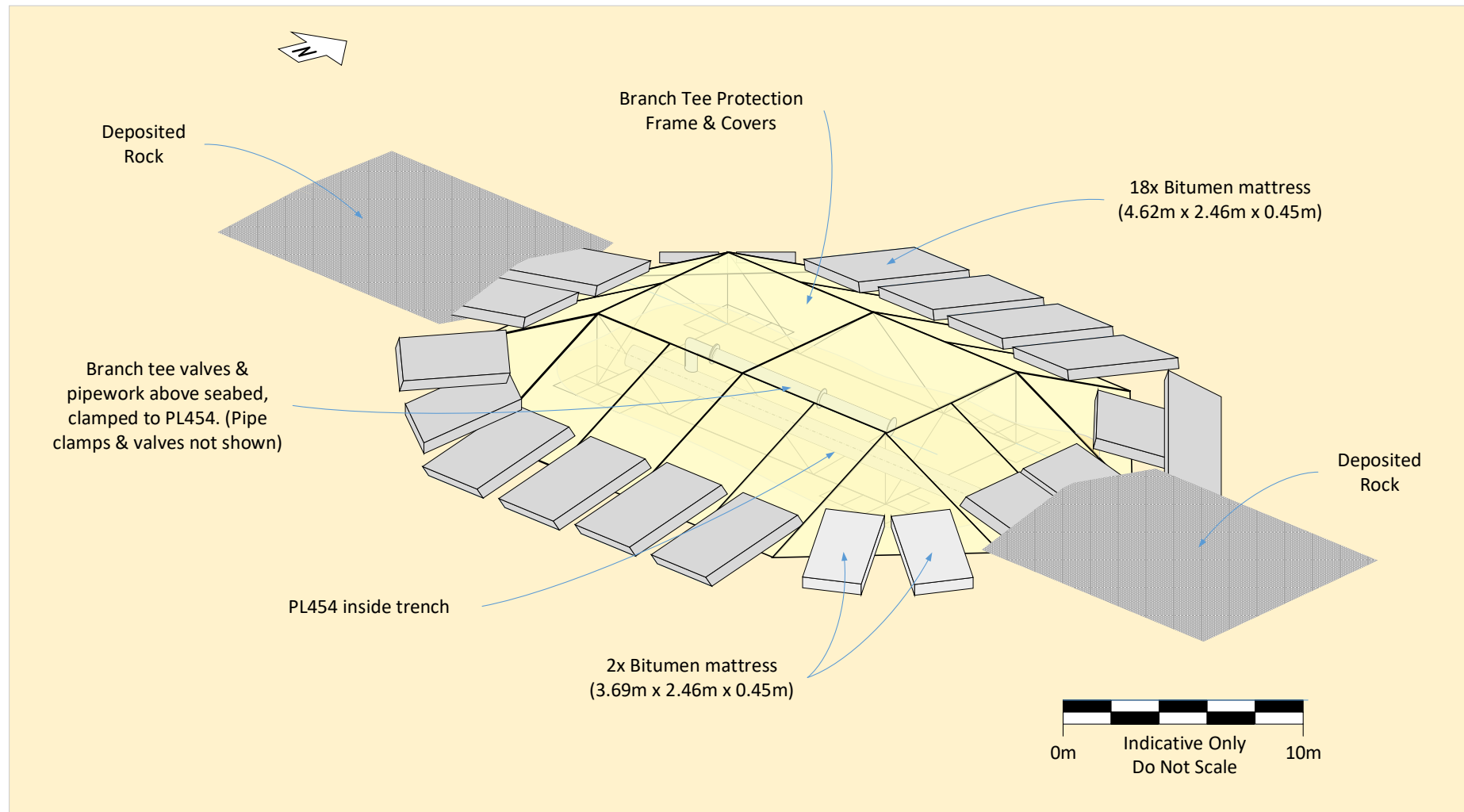

Figure 2.3.2: Schematic Branch Tee No. 1⁵

⁵ All schematics should be considered indicative only; the age of the facilities is such that it has not always been possible to obtain accurate 'as-built' information.

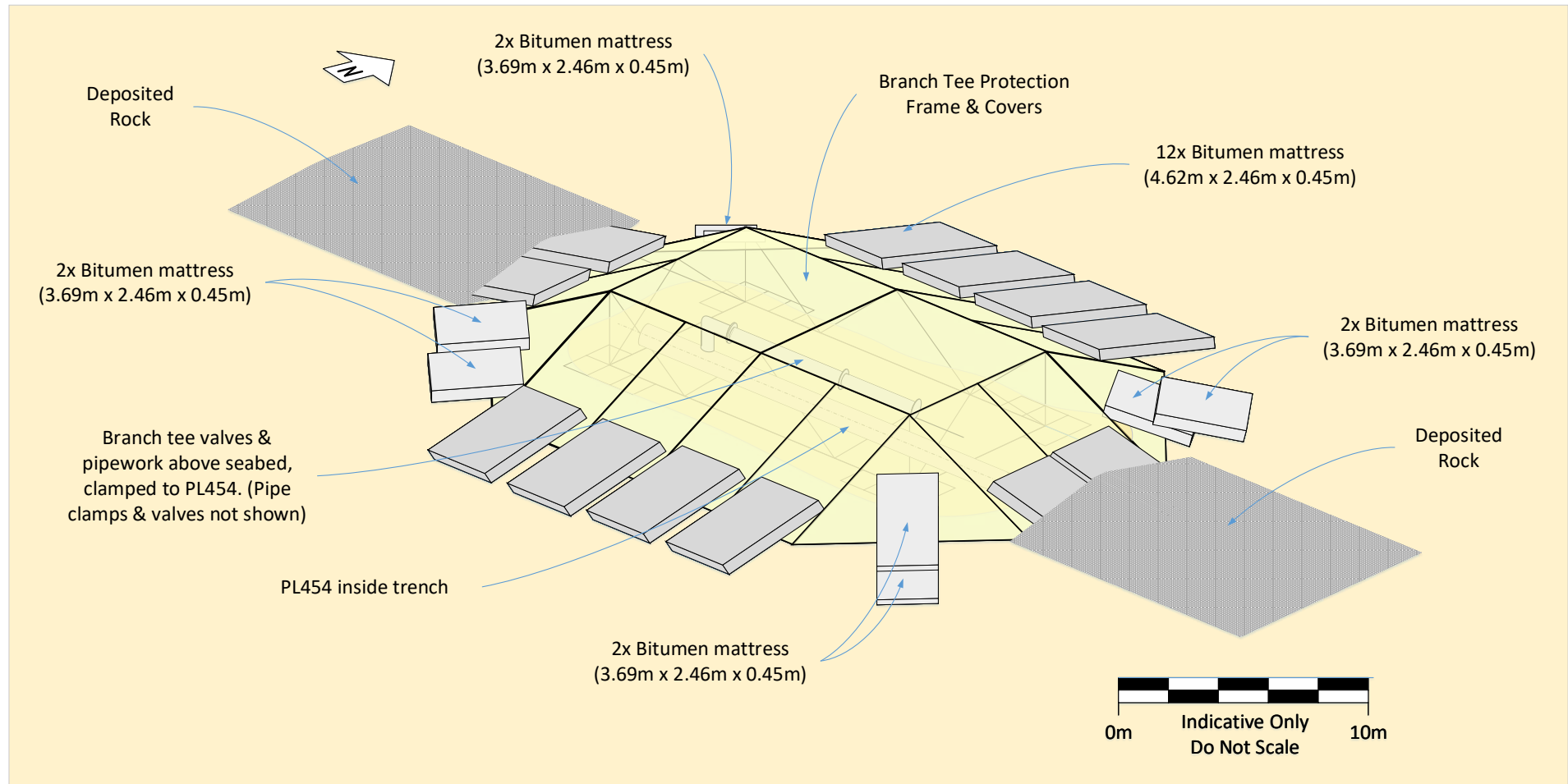

Figure 2.3.3: Schematic Branch Tee No. 2

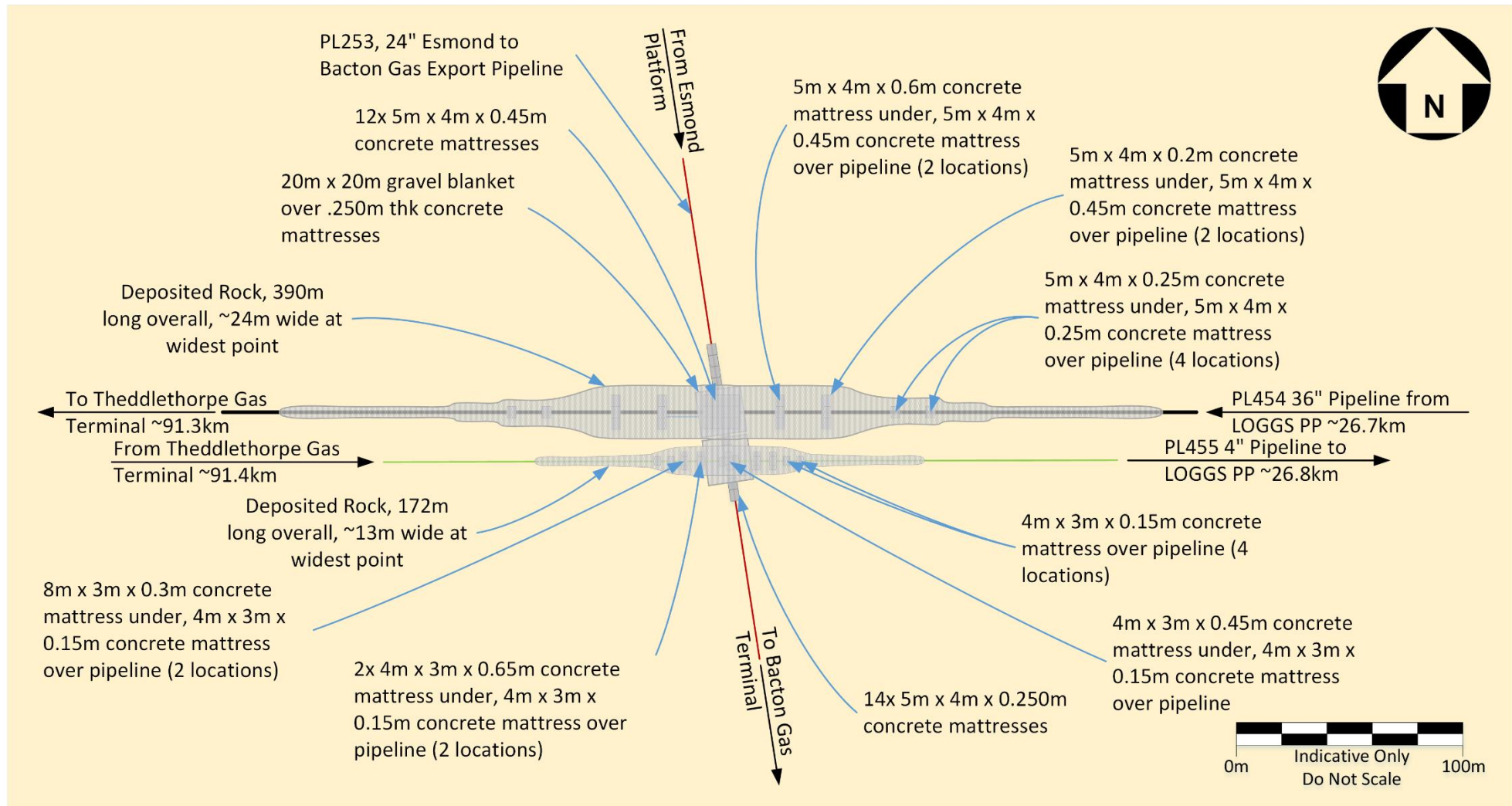

Figure 2.3.4: Pipeline Crossing PL454 & PL455 over PL253

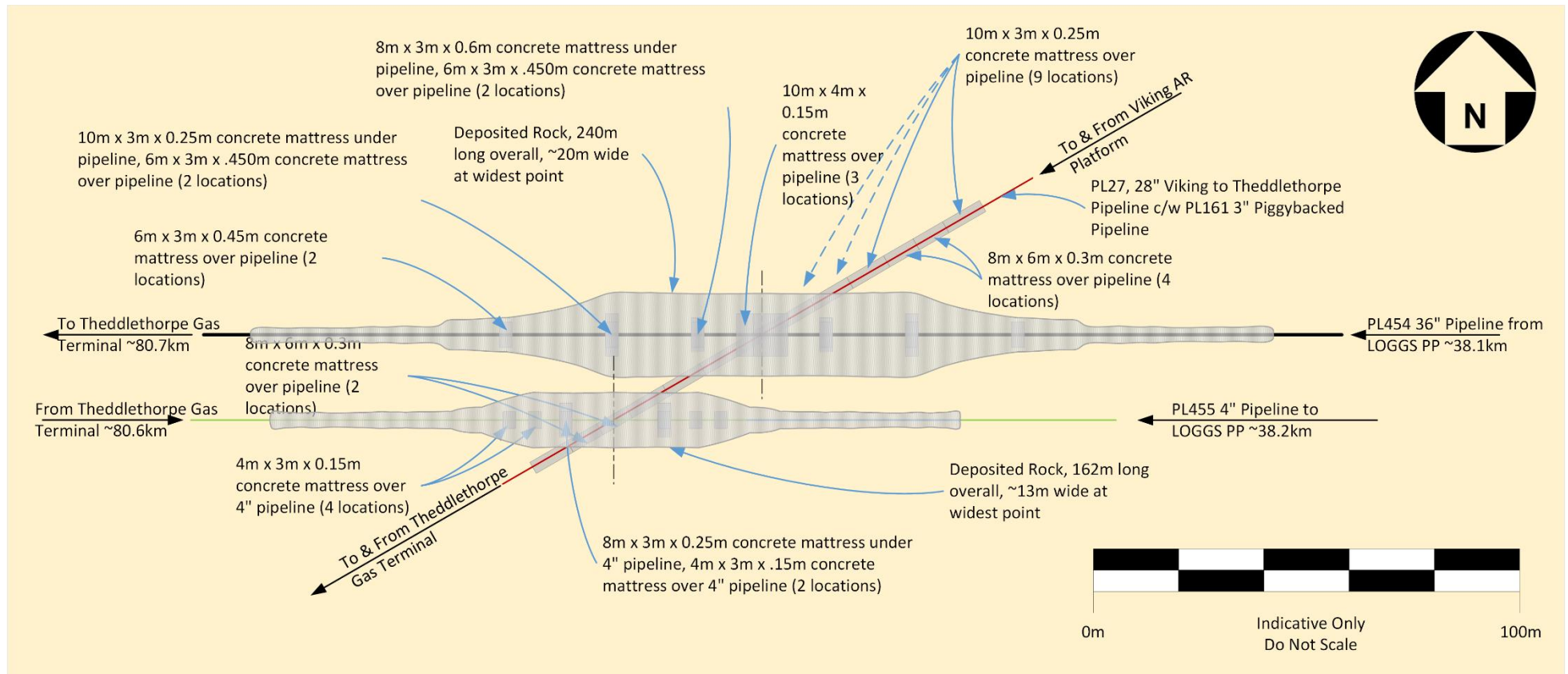

Figure 2.3.5: Pipeline Crossing PL454 & PL455 over PL27 & PL161

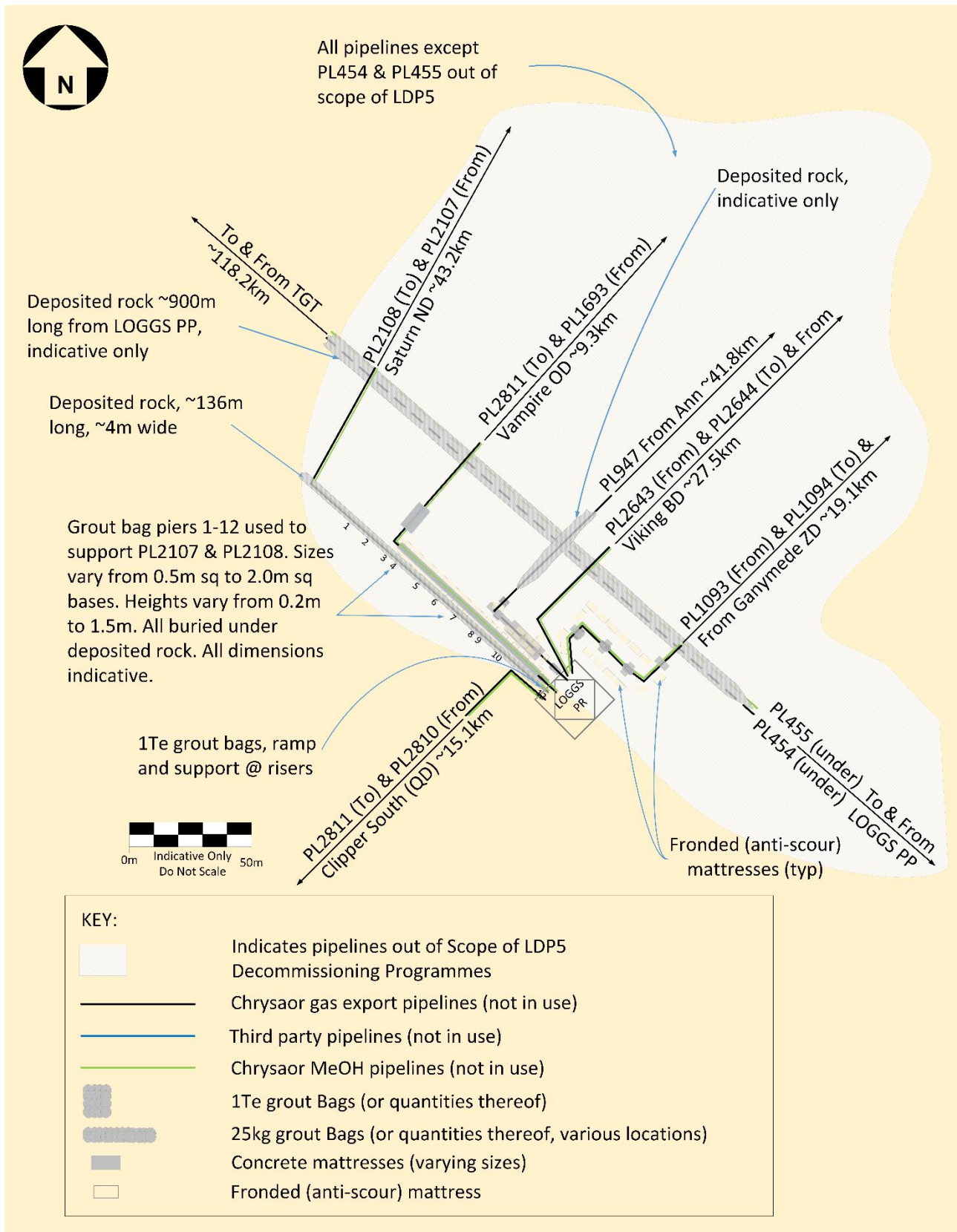

Figure 2.3.6: PL454 & PL455 underneath Third-Party Pipelines at LOGGS PR

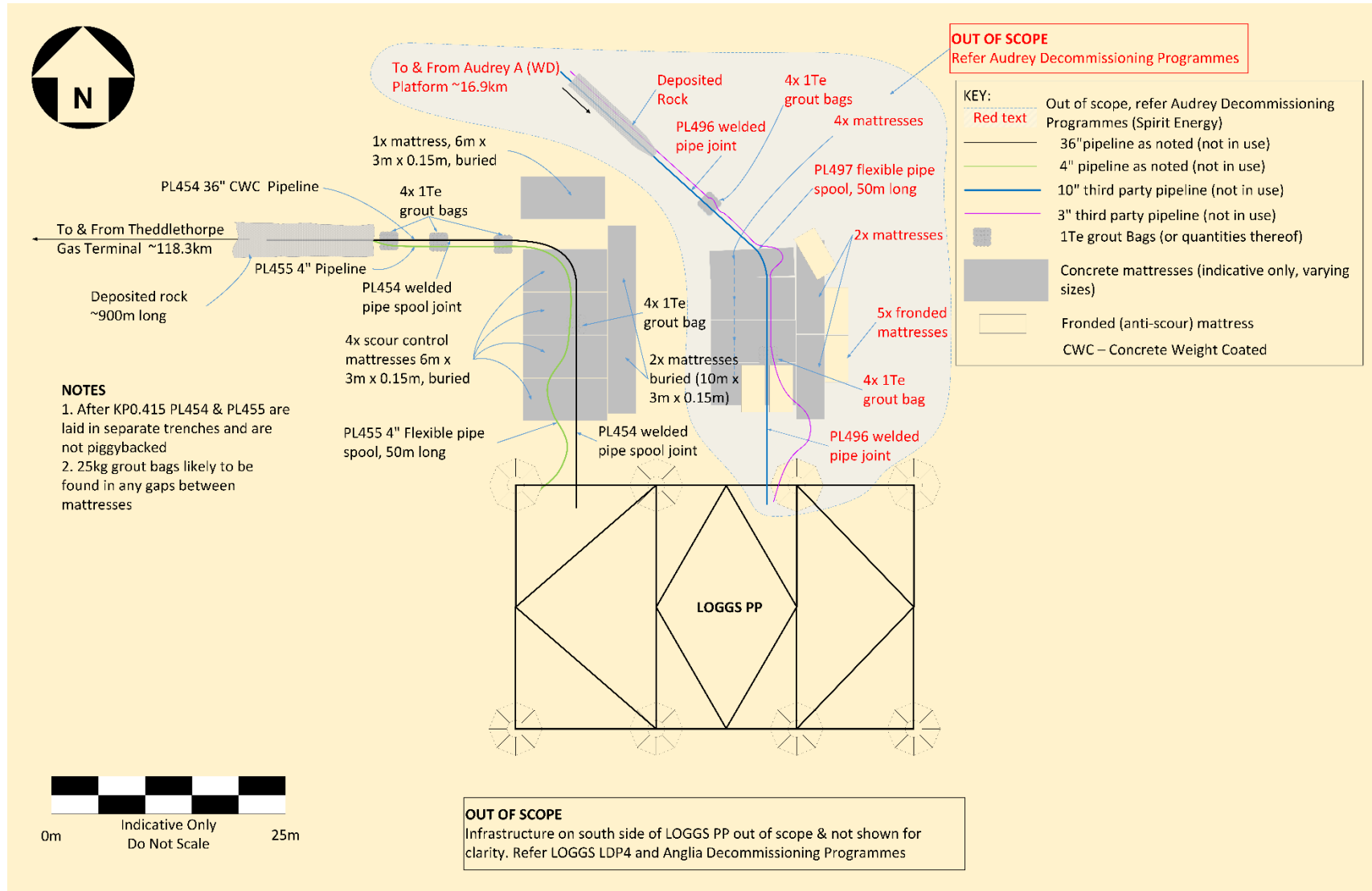

Figure 2.3.7: Approaches & Pipelines LOGGS PP North Side

Table 2.3.3: Subsea Structures and Stabilisation Features

Feature	Total Number	Size/Weight (Te)	Location(s) WGS84 Decimal	Locations(s) WGS84 Decimal Minute	Comments / Status
Branch Tee Protection Structure	1	W x L x H 6m x 13m x 3.5m 73.2Te	53.383637° N 1.616495° E	53° 23.0182' N 01° 36.9897' E	Piled protection structure, 4x piles, 13m penetration into seabed
	1	W x L x H 6m x 13m x 3.5m 71.1Te	53.379272° N 1.242613° E	53° 22.7563' N 01° 14.5568' E	Piled protection structure, 4x piles, 8 m penetration into seabed
Bitumen mattresses	20	261	Branch Tee No. 1 at KP26.2; refer Figure 2.3.2		Varying sizes overlying the branch tee protection structures
	20	288	Branch Tee No. 2 at KP51.6; refer Figure 2.3.3		
Deposited rock ³	36m	811	Branch Tee between KP26.176 to KP26.212 ~36M LG		At ends of branch tee protection structure and not on top
	7m	158	Branch Tee between KP51.591 to KP51.598 ~7M LG		

Table 2.3.4: Subsea Pipeline Stabilisation Features

Stabilisation Feature	Total Number	Total Weight (Te)	Location(s)	Exposed / Buried / Condition
Concrete mattresses	5	38	LOGGS PP Approach (PL454 & PL455), 10m x 5m x 0.15m. Refer Figure 2.3.7	Data suggests that scour protection concrete mattresses underneath the pipelines are buried
	2	5.8	LOGGS PP Approach (PL454 & PL455), 6m x 3m x 0.15m. Refer Figure 2.3.7	Data suggests that scour protection concrete mattresses underneath the pipelines are buried
	72	679	PL253 Pipeline Crossing. Refer Figure 2.3.4	Some but not all buried under deposited rock
	31	345	PL27 & PL161 Pipeline Crossings. Refer Figure 2.3.5	Some but not all buried under deposited rock
Grout bags ¹ (1Te)	16	16	LOGGS PP Approach (PL454 & PL455), 4x4 1Te grout bags at four locations. Refer Figure 2.3.7	Data suggests that these will likely be exposed
Grout bags ² (25kg)	120	3.0	LOGGS PP Approach, in between 4x 6m x 3m mattresses underneath PL454 & PL455. Refer Figure 2.3.7	Data suggests that if these exist these will be buried along with the scour protection

Table 2.3.4: Subsea Pipeline Stabilisation Features

Stabilisation Feature	Total Number	Total Weight (Te)	Location(s)	Exposed / Buried / Condition
	133	3.4	LOGGS PP Approach, in between 10m x 5m mattresses east of PL454 & PL455. Refer Figure 2.3.7	concrete mattresses.
	33	0.8	LOGGS PP Approach, north-south in between 4x 6m x 3m mattresses and 10m x 5m mattresses east of PL454 & PL455. Refer Figure 2.3.7	
Deposited rock ^{3,4}	900m	5,983	PL454 On Approach to LOGGS PP KP0 to KP0.9 ~900m long	Much of the deposited rock was installed inside the trenches at the approaches and transitions and on top of the pipelines elsewhere; significant lengths of deposited rock appear to be buried in seabed sediment
	81m	315	PL455 at transition from being piggybacked in PL454 to being laid in a separate trench	
	27m	608	PL454 KP12.337 to KP12.364 ~27m long	
	17m	383	PL454 KP19.937 to KP19.954 ~17m long	
	390m	19,050	PL253 Pipeline Crossing. Refer Figure 2.3.4	
	172m	4,056		
	15m	338	PL454 KP27.142 to KP27.157 ~15m long	
	10m	225	PL454 KP27.406 to KP27.416 ~10M LG	
	20m	451	PL454 KP27.429 to KP27.449 ~20M LG	
	240m	9,537	PL27 & PL161 Pipeline Crossings. Refer Figure 2.3.5	
	162m	5,211		
150m	3,379	PL455 at transition from being laid in a separate trench to being piggybacked to PL454		

NOTES:

1. Notional number of grout bags as as-built data are not explicit. Numbers are estimated and based on sketches prepared for inspection activities;
2. Quantity of 25kg grout bags is not specified on any as-built drawings and is a notional figure based on location of scour protection concrete mattresses;
3. Weight of deposited rock is estimated, based on the estimated volume and profile using a density 2.650 Te/m³;
4. Quantity of deposited rock excludes rock used to protect and stabilise pipeline crossings installed after PL454 and PL455.

2.4 Wells

North Valiant (1) PD Platform Wells	Designation	Status	Category of Well
49/16-P01	Gas Production	Decommissioned	PL 3-3-3
49/16-P02	Gas Production	Decommissioned	PL 3-3-3
49/16-P03	Gas Production	Decommissioned	PL 3-3-3
49/16-P04	Gas Production	Decommissioned	PL 3-3-3
49/16-P05	Gas Production	Decommissioned	PL 3-4-3
49/16-P06z	Gas Production	Decommissioned	PL 3-3-3
49/16-P07z	Gas Production	Decommissioned	PL 3-4-3

For details of well categorisation see the latest version of the Oil & Gas UK Guidelines for the Decommissioning of Wells.

2.5 Inventory Estimates

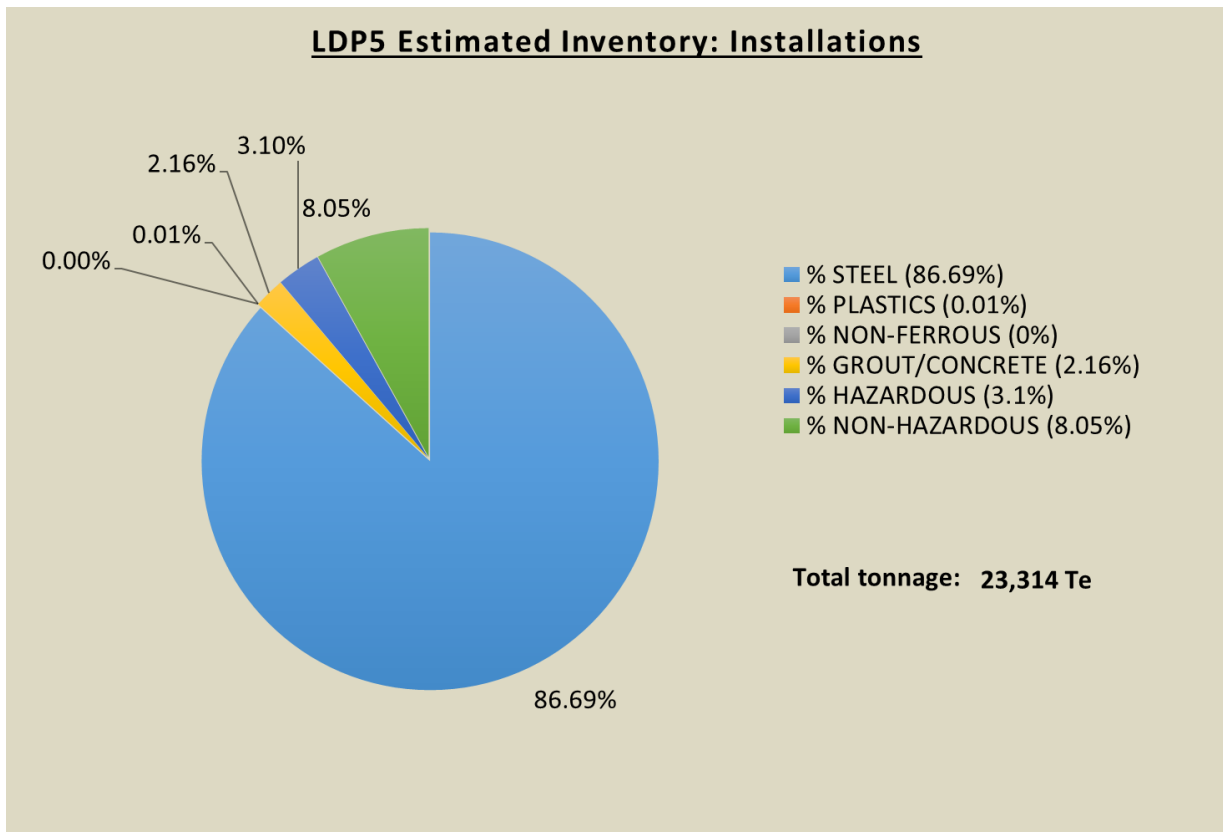

Figure 2.5.1: Pie-chart of estimated installation inventory

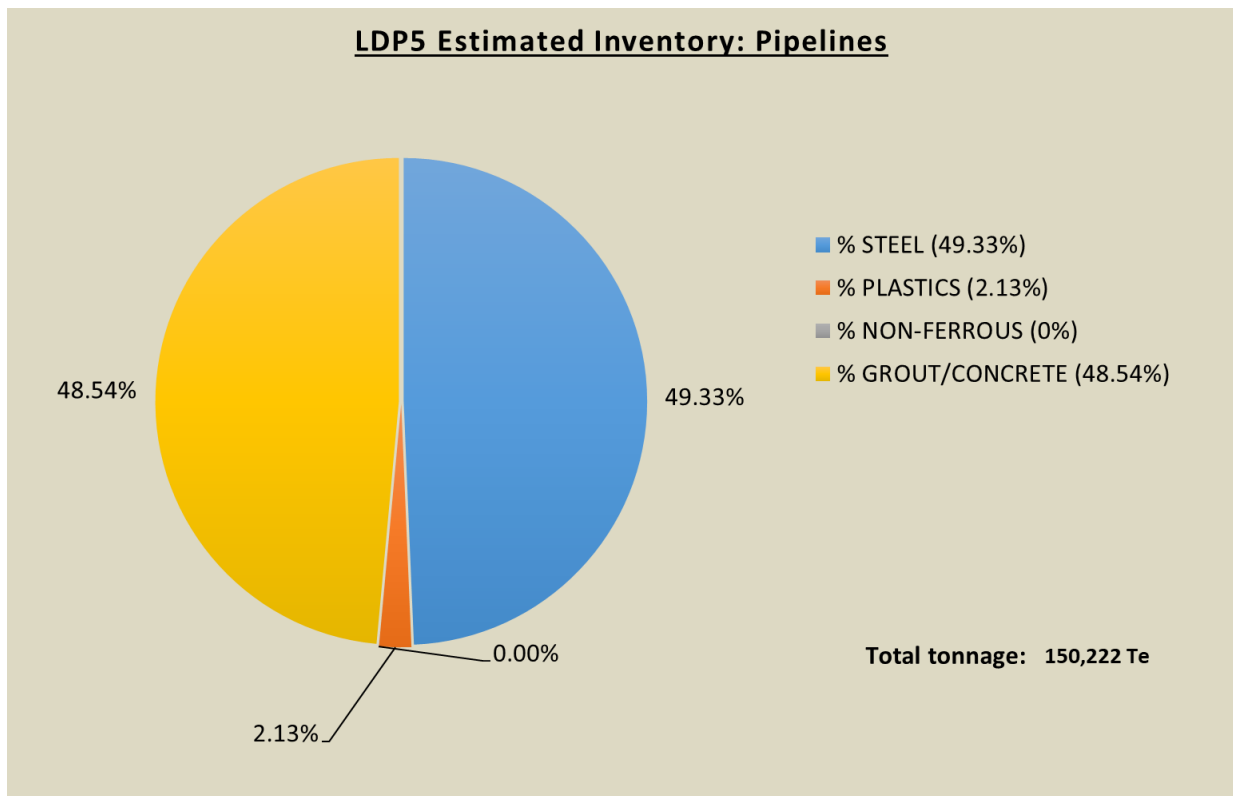

Figure 2.5.2: Pie-chart of estimated pipeline inventory, excluding deposited rock

3 Removal and Disposal Methods

Waste will be dealt with in accordance with the Waste Framework Directive. The reuse of an installation or pipelines (or parts thereof) is first in the order of preferred decommissioning options. However, given the age of the installations and infrastructure it is unlikely that reuse opportunities will be realised. Waste generated during decommissioning will be segregated by type and periodically transported to shore in an auditable manner through licensed waste contractors. Transfrontier shipment of waste will not be required. Steel and other recyclable metal are estimated to account for the greatest proportion of the materials inventory. Refer to section 5.4 of the Environmental Appraisal [3] for further details concerning disposal of waste.

3.1 Topsides Decommissioning

3.1.1 LOGGS PR

Topsides description: the LOGGS PR topside structure comprises a Main Deck, Cellar Deck, ESDV Deck and Spider Deck as illustrated in Figure 3.1.1 and weighs ~2,499Te including the weight of the bridge to LOGGS PC, which is ~106.7Te. The overall dimensions of the Main Deck are ~35m x 35m and the overall height between the Main Deck and LAT is ~29.9m. The bridge link between LOGGS PR and LOGGS PC is visible in Figure 2.1.3 and Figure 2.1.4. The bridge has a cross section 5.5m deep x 4m wide and is ~30m long.

Removal methods: the topsides will be completely removed and returned to shore. Possible methods are described in Table 3.1.2.

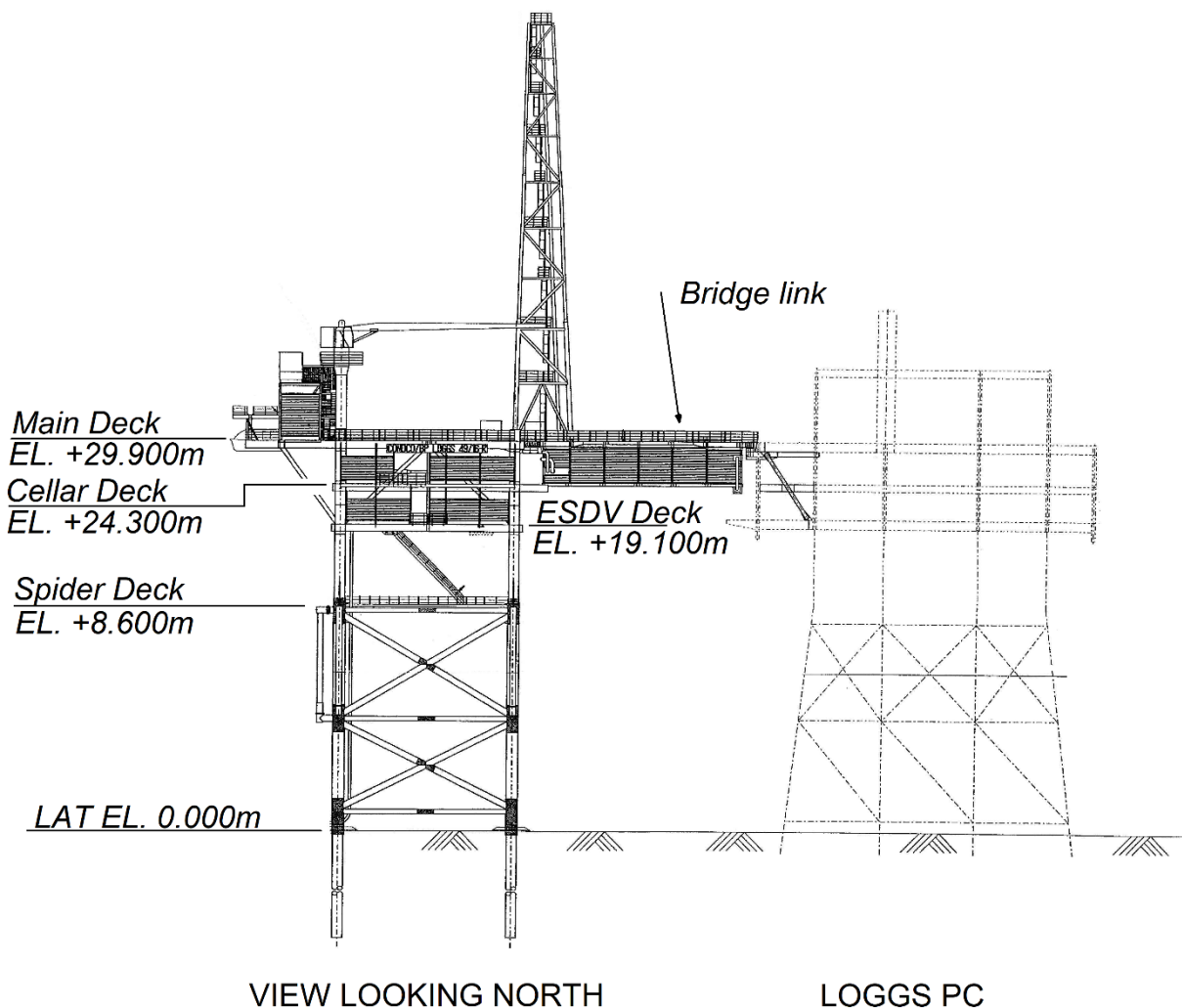

Figure 3.1.1: View on LOGGS PR Topsides Looking North

3.1.2 LOGGS PC

Topsides description: the LOGGS PC topside structure comprises an Air Cooler Deck, Main Deck, Intermediate Deck, and Cellar Deck as illustrated in Figure 3.1.2 and weighs ~4,752Te including the weight of the bridge to LOGGS PP, which is ~46.7Te. There is also a small Spider Deck, but this is not shown in the illustration. The overall dimensions of the Main Deck are ~45m x 32m and the overall height between the Air Cooler Deck and LAT is ~39.4m. The bridge link between LOGGS PC and LOGGS PP are not shown here but are visible in Figure 2.1.3 and Figure 2.1.6. The bridge has a cross section 5m deep x 4m wide and is ~22m long.

Removal methods: the topsides will be completely removed and returned to shore. Possible methods are described in Table 3.1.2.

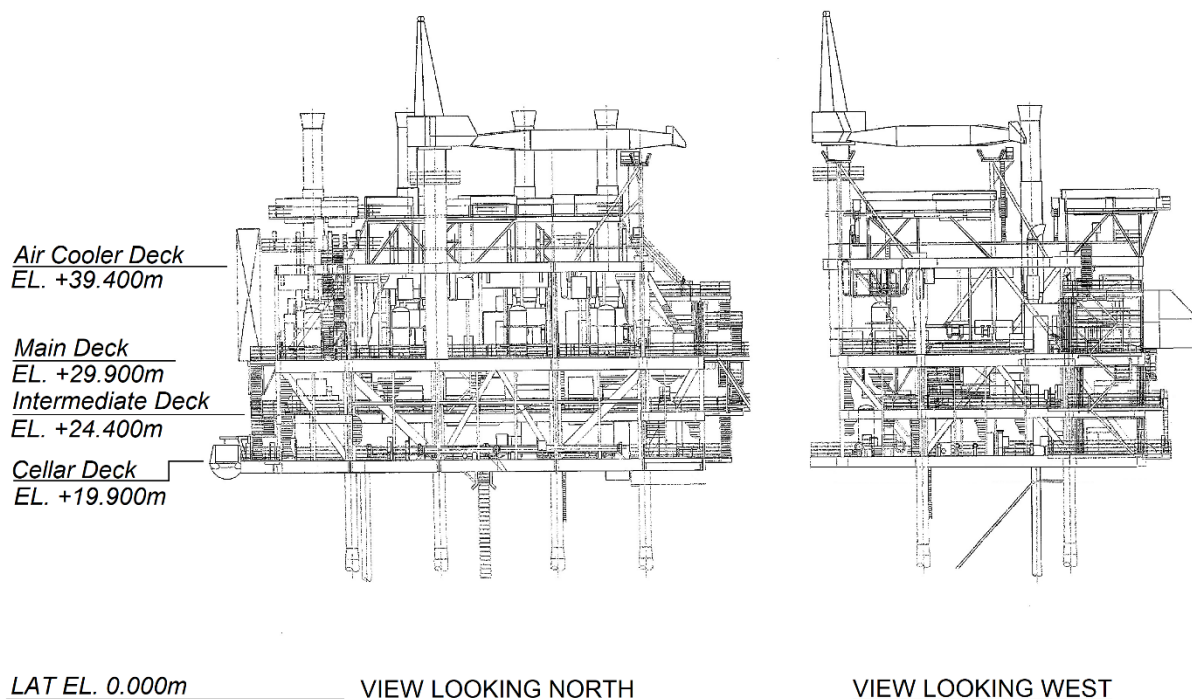

Figure 3.1.2: View on LOGGS PC Topsides Looking North & West

3.1.3 LOGGS PP

Topsides description: the LOGGS PP topside structure comprises a Main Deck, Intermediate Deck, and Cellar Deck and Spider Deck as illustrated in Figure 3.1.3 and weighs ~3,950Te. The overall dimensions of the Main Deck are ~44m x 31m and the overall height between the Main Deck and LAT is ~29.9m. The various bridge links between LOGGS PP and LOGGS PC, LOGGS PA and North Valiant PD are not shown here but are visible in Figure 2.1.3, Figure 2.1.6, Figure 2.1.7 and Figure 2.1.8. The weights and dimensions for the bridge links are explained in the individual descriptions for LOGGS PC, North Valiant PD and LOGGS PA and so shall not be repeated here.

Removal methods: the topsides will be completely removed and returned to shore. Possible methods are described in Table 3.1.2.

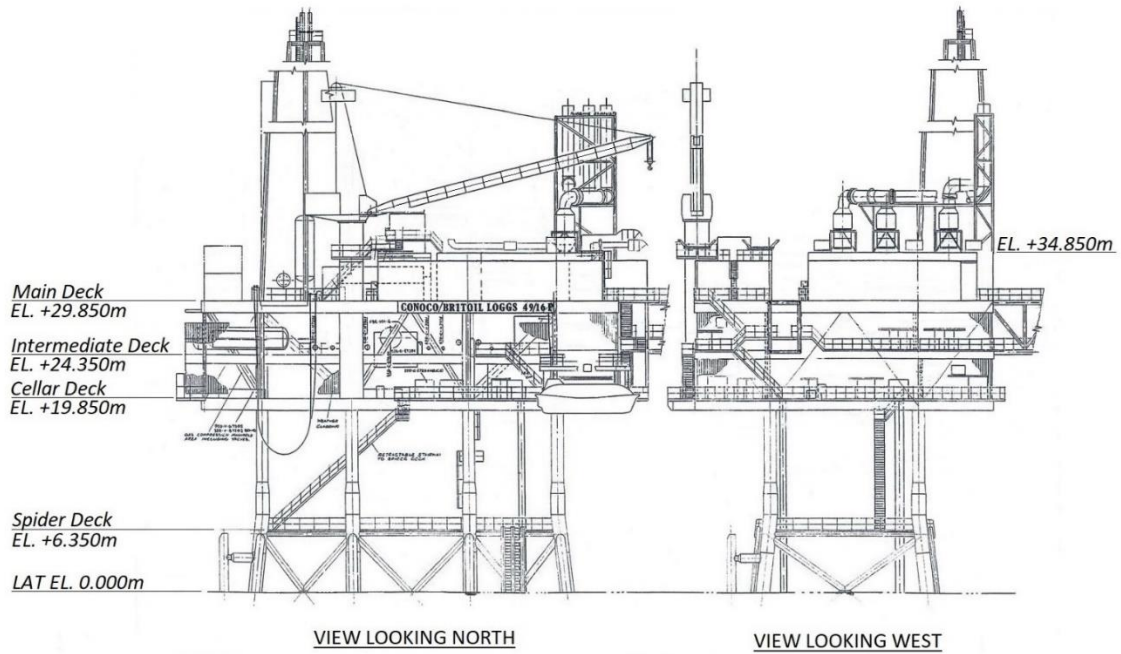

Figure 3.1.3: View on LOGGS PP Topsides Looking North & West

3.1.4 LOGGS PA

Topsides description: the LOGGS PA topside structure comprises a Helideck, Roof, Bottom Level and Spider Deck as illustrated in Figure 3.1.4 and weighs ~2,418Te including the weight of the bridge to LOGGS PP, which is ~77.4Te. The overall dimensions of the Main Deck are ~29m x 29m and the overall height between the Helideck and LAT is ~43.6m. The bridge has a cross section 7m deep x 3m wide and is ~25m long.

Removal methods: the topsides will be completely removed and returned to shore. Possible methods are described in Table 3.1.2.

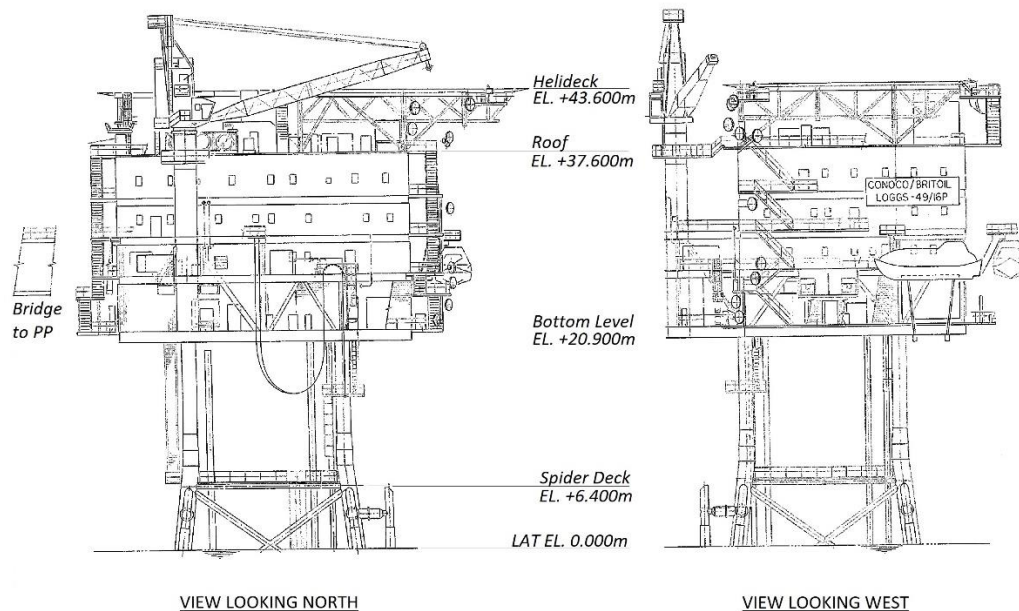

Figure 3.1.4: View on LOGGS PA Topsides Looking North & West

3.1.5 North Valiant PD

Topsides description: The North Valiant PD topsides comprises a Main Deck, Cellar Deck and Spider Deck as illustrated in Figure 3.1.5 and weighs 602Te including the weight of the bridge to LOGGS PP, which is ~42Te. The dimensions of the Main Deck are ~26m x 21m and the overall height between the Main Deck and LAT is ~29.9m. The bridge link between LOGGS PP and North Valiant PD is visible in Figure 2.1.3 and Figure 2.1.4. The bridge has a cross section 5m deep x 3m wide and is ~30m long.

Removal methods: the topsides will be completely removed and returned to shore. Possible methods are described in Table 3.1.2.

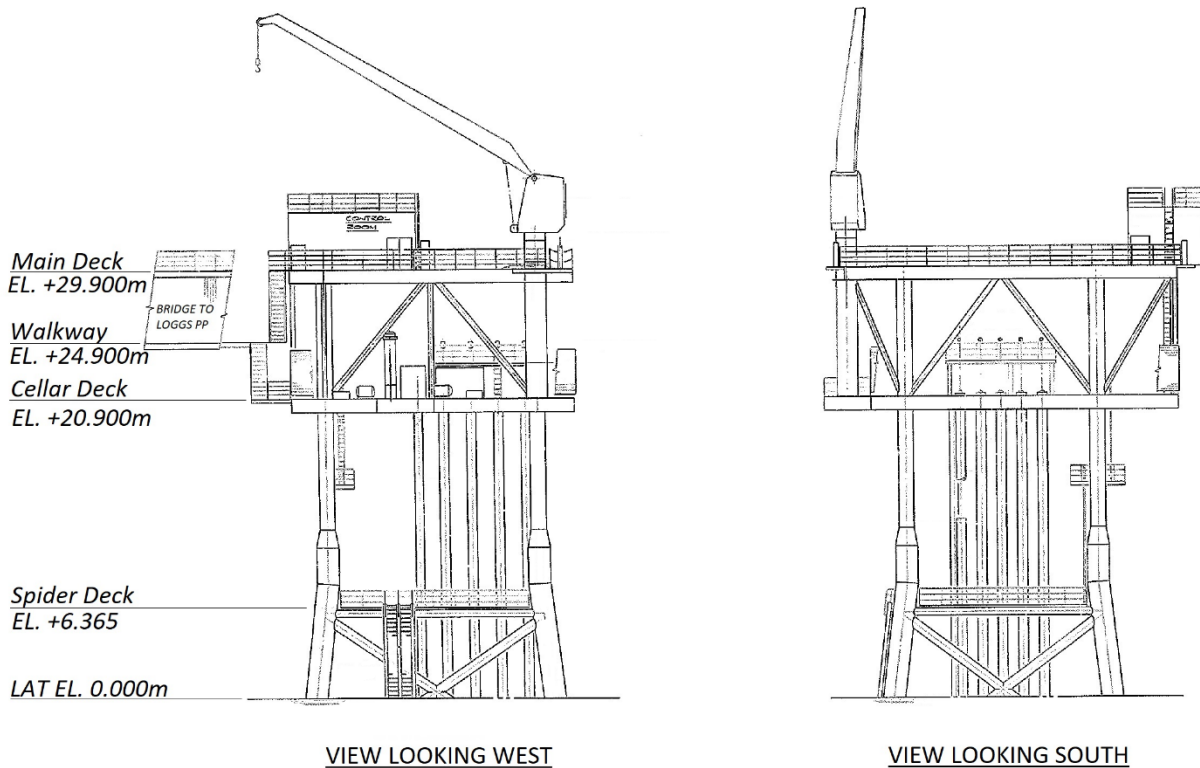

Figure 3.1.5: View on North Valiant PD Topsides Looking West & South

Preparation / Cleaning: The methods that will be used to flush, purge and clean the topsides prior to removal to shore are summarised in Table 3.1.1.

Table 3.1.1: Cleaning of Topsides for Removal		
Waste Type	Composition of Waste	Disposal Route
Hydrocarbons	Process fluids	Vessels and pipework have already been flushed, nitrogen purged vented and made liquid free.
Produced solids	Sand, NORM	Any pipeline debris captured in filter packages, has been returned onshore for disposal. Any solids remaining in vessels has already been removed and disposed of during the dismantlement of the Topsides onshore.
Diesel	Bunkered Diesel fuel	Bunkered diesel has already been drained and returned onshore for re-use or disposal.
Lubricating oils	Lubricants for equipment e.g. gearboxes, pumps, pedestal crane compressor skid	Lubricating oils have already been drained and returned onshore for re-use or disposal.

3.1.6 Topsides Removal Methods

Table 3.1.2: Topsides Removal Methods	
1) Semi-Submersible Crane Vessel <input checked="" type="checkbox"/> ; 2) Monohulled Crane Vessel <input checked="" type="checkbox"/> ; 3) Shear Leg Vessel <input checked="" type="checkbox"/> ; 4) Jack up Work barge <input checked="" type="checkbox"/> ; 5) Piece small or large <input checked="" type="checkbox"/> ; 6) Complete with jacket <input checked="" type="checkbox"/>	
Methods Considered	Description
Single lift removal by SSCV / MCV / SLV	Removal of topsides and jacket as a complete unit followed by recovery to shore for re-use, recycling, and disposal as appropriate
Single lift removal by SSCV / MCV / SLV	Removal of topsides as a single unit followed by recovery to shore for re-use, recycling, disposal as appropriate
Piece-small or piece large removal using attendant support vessel such as a JUWB	Removal of topsides in a series of smaller sub-units making use of the JUWB used for the well decommissioning activities, followed by recovery to shore for a programme of re-use, recycling or disposal as appropriate
Proposed removal method and disposal route	Removal of both topsides and jacket individually followed by recovery to shore for reuse, recycling, and final disposal to landfill as appropriate. A final decision on the decommissioning method was made following a commercial tendering process and the removal contract has now been awarded. Removal will be carried out using an SSCV.

3.2 Jacket Decommissioning

3.2.1 LOGGS PR

Jacket description: The 4-legged jacket (Figure 3.2.1) weighs ~1,870Te excluding the section of piles penetrating more than 3m into the seabed and excluding any rigging that would be used for lifting operations. The legs will be cut at an appropriate elevation to allow the lifting aids to be installed, and the jackets will ideally each be removed in a single lift⁶. Assuming there would be no technical issues, the piles will be internally cut 3.0m below the seabed. If any difficulties are encountered in accessing the piles internally such that an excavation will be required, OPRED will be consulted before the piles are cut. The jacket will be returned to shore for recycling.

Removal methods: the jacket along with mud mats and all the risers will be completely removed and returned to shore. Possible methods are described in Table 3.2.1.

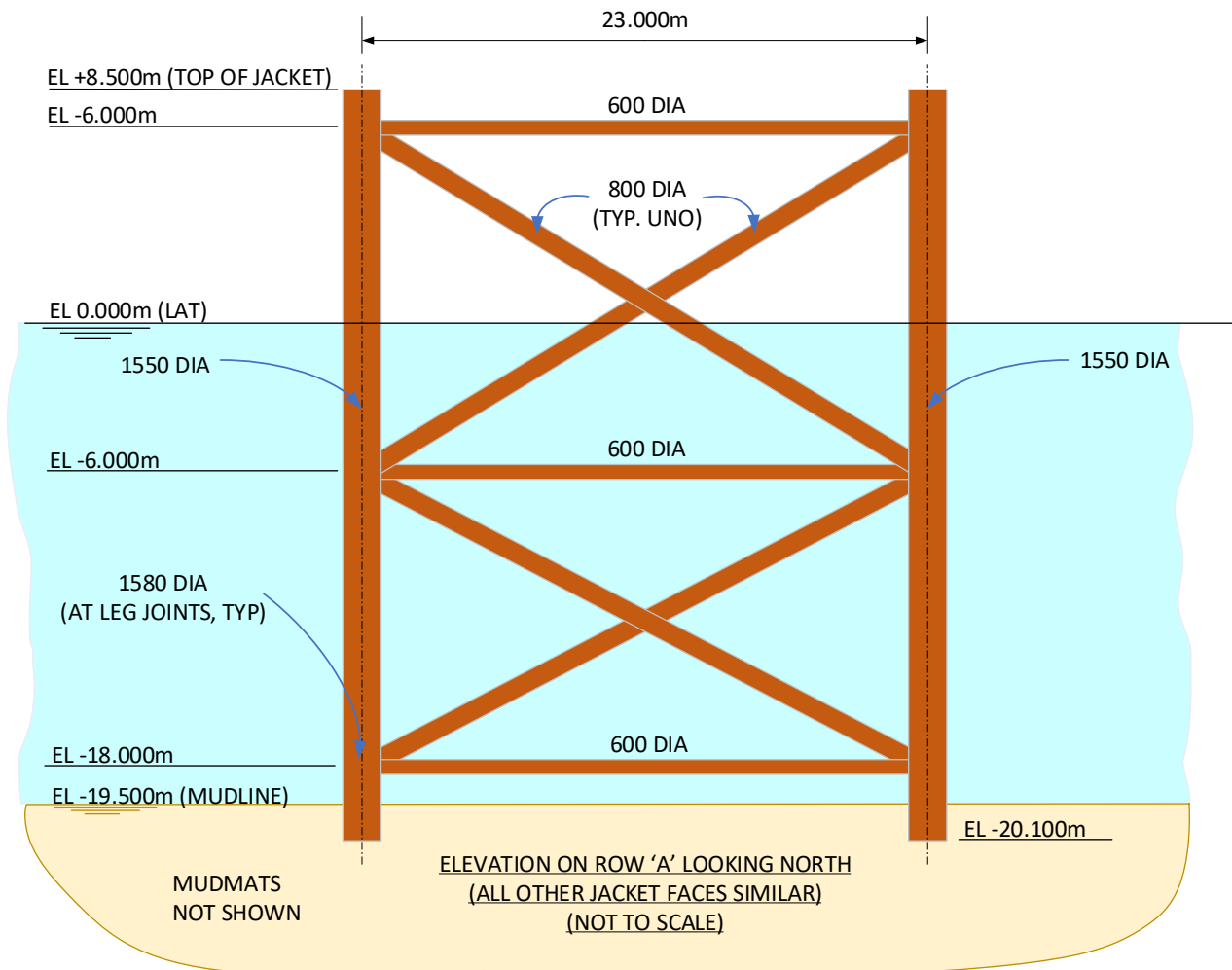

Figure 3.2.1: LOGGS PR Jacket Typical View

3.2.2 LOGGS PC

Jacket description: The 8-legged jacket (Figure 3.2.2 & Figure 3.2.3) weighs ~2,109Te excluding the section of piles penetrating more than 3m into the seabed and excluding any rigging that would be used for lifting operations. The legs will be cut at an appropriate elevation to allow the lifting aids to be installed, and the

⁶ The technique adopted for removal of the jacket will be subject to engineering feasibility and any commercial agreements.

jackets will ideally each be removed in a single lift⁷. Assuming there would be no technical issues, the piles will be internally cut 3.0m below the seabed. If any difficulties are encountered in accessing the piles internally such that an excavation will be required, OPRED will be consulted before the piles are cut. The jacket will be returned to shore for recycling.

Removal methods: the jacket along with mud mats will be completely removed and returned to shore. Possible methods are described in Table 3.2.1.

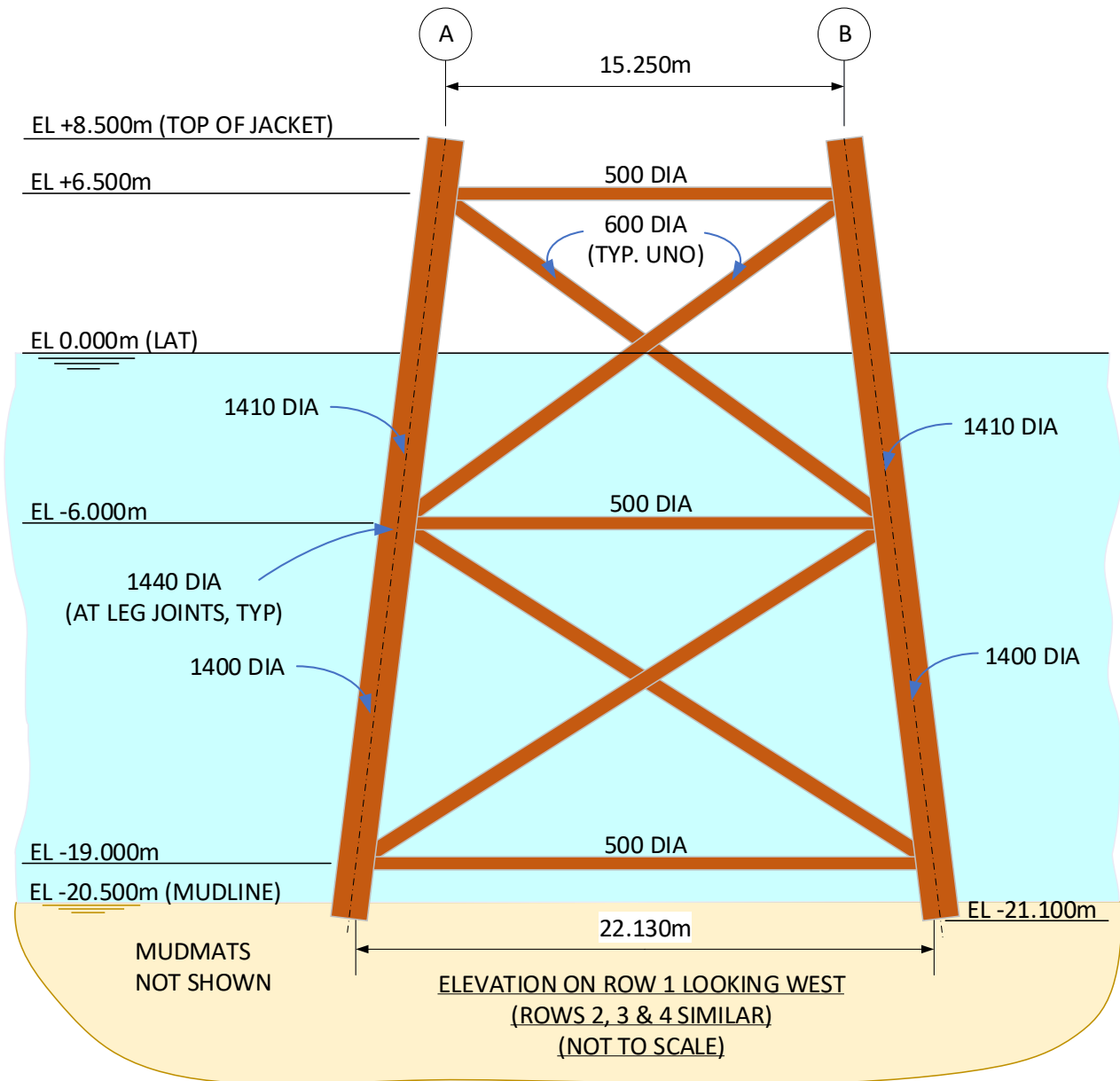

Figure 3.2.2: LOGGS PC Jacket View Looking West

⁷ The technique adopted for removal of the jacket will be subject to engineering feasibility and any commercial agreements.

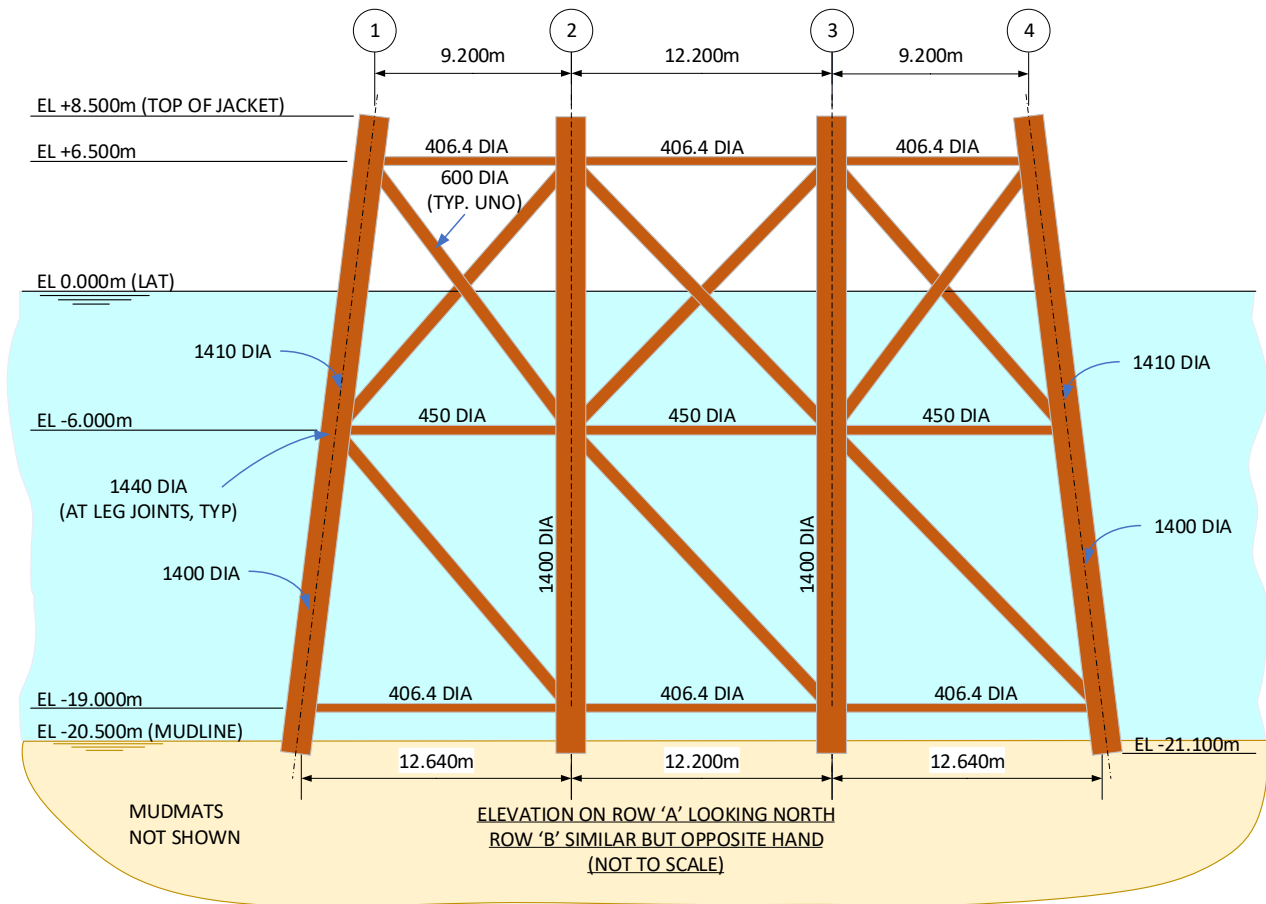

Figure 3.2.3: LOGGS PC Jacket View Looking North

3.2.3 LOGGS PP

Jacket description: The 8-legged jacket (Figure 3.2.4, Figure 3.2.5) weighs ~2,347Te excluding the section of piles penetrating more than 3m into the seabed and excluding any rigging that would be used for lifting operations. The legs will be cut at an appropriate elevation to allow the lifting aids to be installed, and the jacket will ideally be removed in a single lift⁸. Assuming there would be no technical issues, the piles will be internally cut 3.0m below the seabed. If any difficulties are encountered in accessing the piles internally such that an excavation will be required, OPRED will be consulted before the piles are cut. The jacket will be returned to shore for recycling.

Removal methods: the jacket along with mud mats and all the risers will be completely removed and returned to shore. Possible methods are described in Table 3.2.1.

⁸ The technique adopted for removal of the jacket will be subject to engineering feasibility and any commercial agreements.

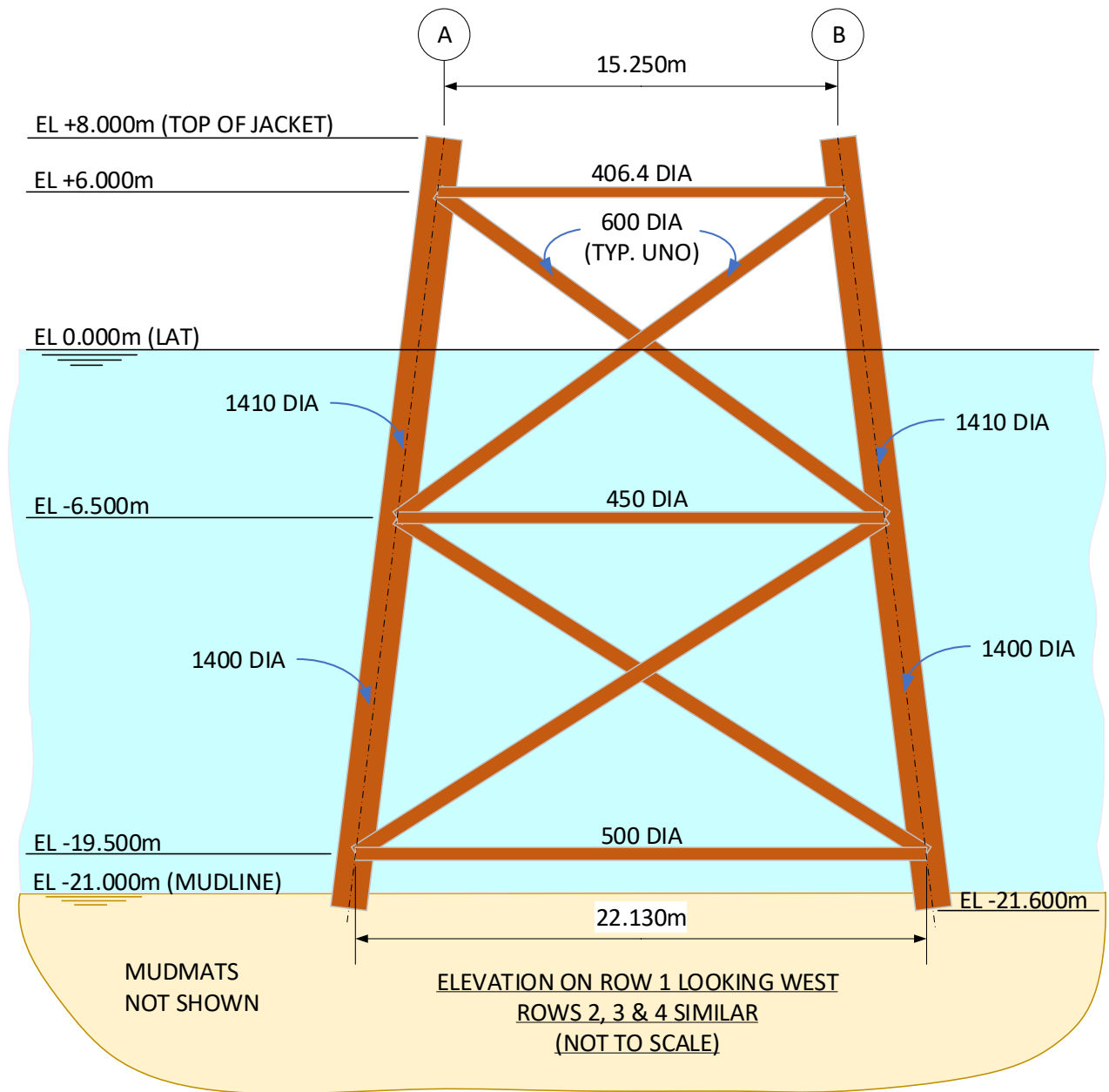

Figure 3.2.4: LOGGS PP Jacket View Looking West

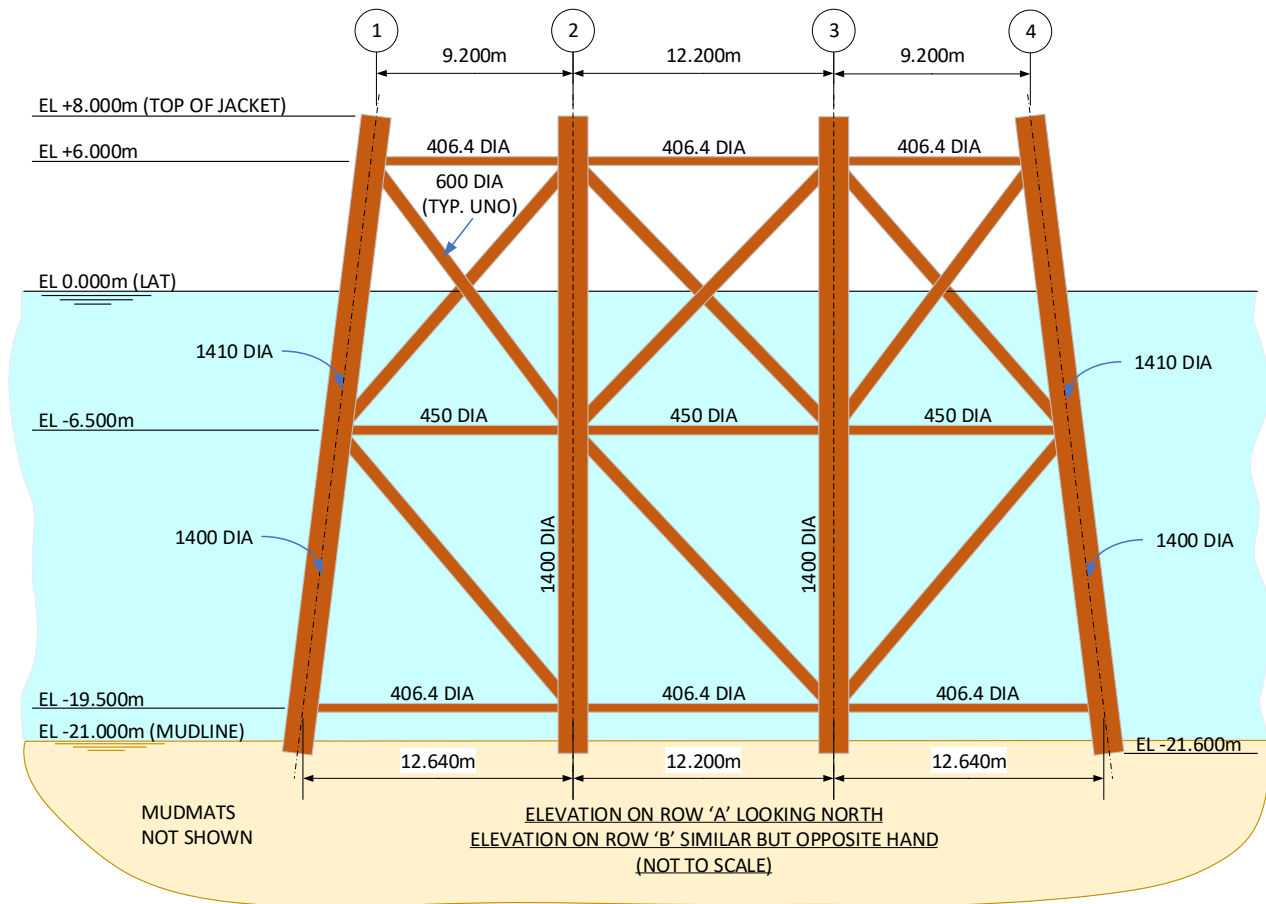

Figure 3.2.5: LOGGS PP Jacket View Looking North

3.2.4 LOGGS PA

Jacket description: The 4-legged jacket (Figure 3.2.6) weighs ~1,444Te excluding the section of piles penetrating more than 3m into the seabed and excluding any rigging that would be used for lifting operations. The legs will be cut at an appropriate elevation to allow the lifting aids to be installed, and the jackets will ideally each be removed in a single lift⁹. Assuming there would be no technical issues, the piles will be internally cut 3.0m below the seabed. If any difficulties are encountered in accessing the piles internally such that an excavation will be required, OPRED will be consulted before the piles are cut. The jacket will be returned to shore for recycling.

Removal methods: the jacket along with the mud mats will be completely removed and returned to shore. Possible methods are described in Table 3.2.1.

⁹ The technique adopted for removal of the jacket will be subject to engineering feasibility and any commercial agreements.

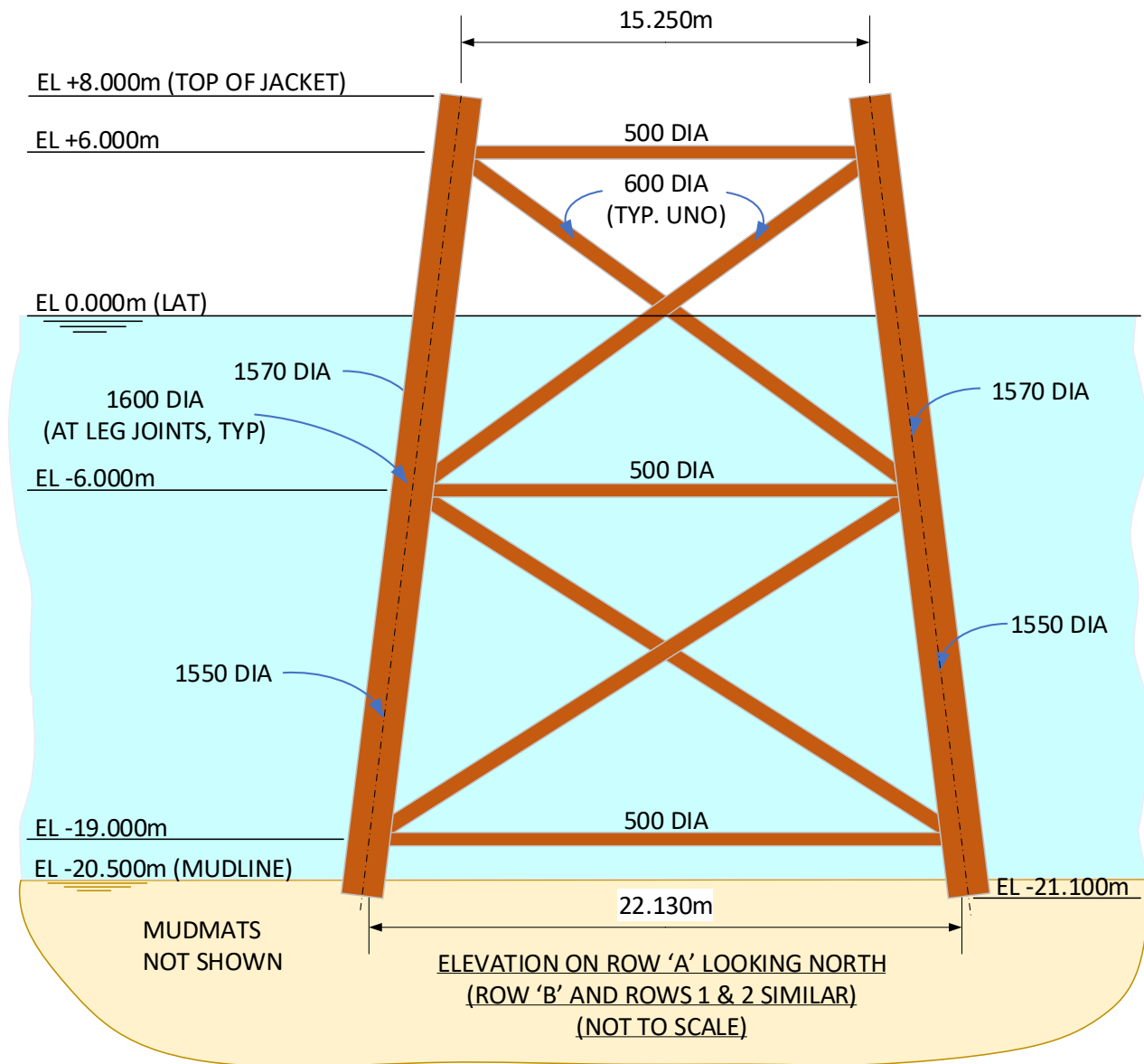

Figure 3.2.6: LOGGS PA Jacket Typical View

3.2.5 North Valiant PD

Jacket description: The 4-legged jacket (Figure 3.2.7, Figure 3.2.8) weighs ~1,324Te excluding the section of piles penetrating more than 3m into the seabed and excluding any rigging that would be used for lifting operations. The legs will be cut at an appropriate elevation to allow the lifting aids to be installed, and the jackets will ideally each be removed in a single lift¹⁰. Assuming there would be no technical issues, the piles will be internally cut 3.0m below the seabed. If any difficulties are encountered in accessing the piles internally such that an excavation will be required, OPRED will be consulted before the piles are cut. The jacket will be returned to shore for recycling.

Removal methods: the jacket along with the mud mats will be completely removed and returned to shore. Possible methods are described in Table 3.2.1.

¹⁰ The technique adopted for removal of the jacket will be subject to engineering feasibility and any commercial agreements.

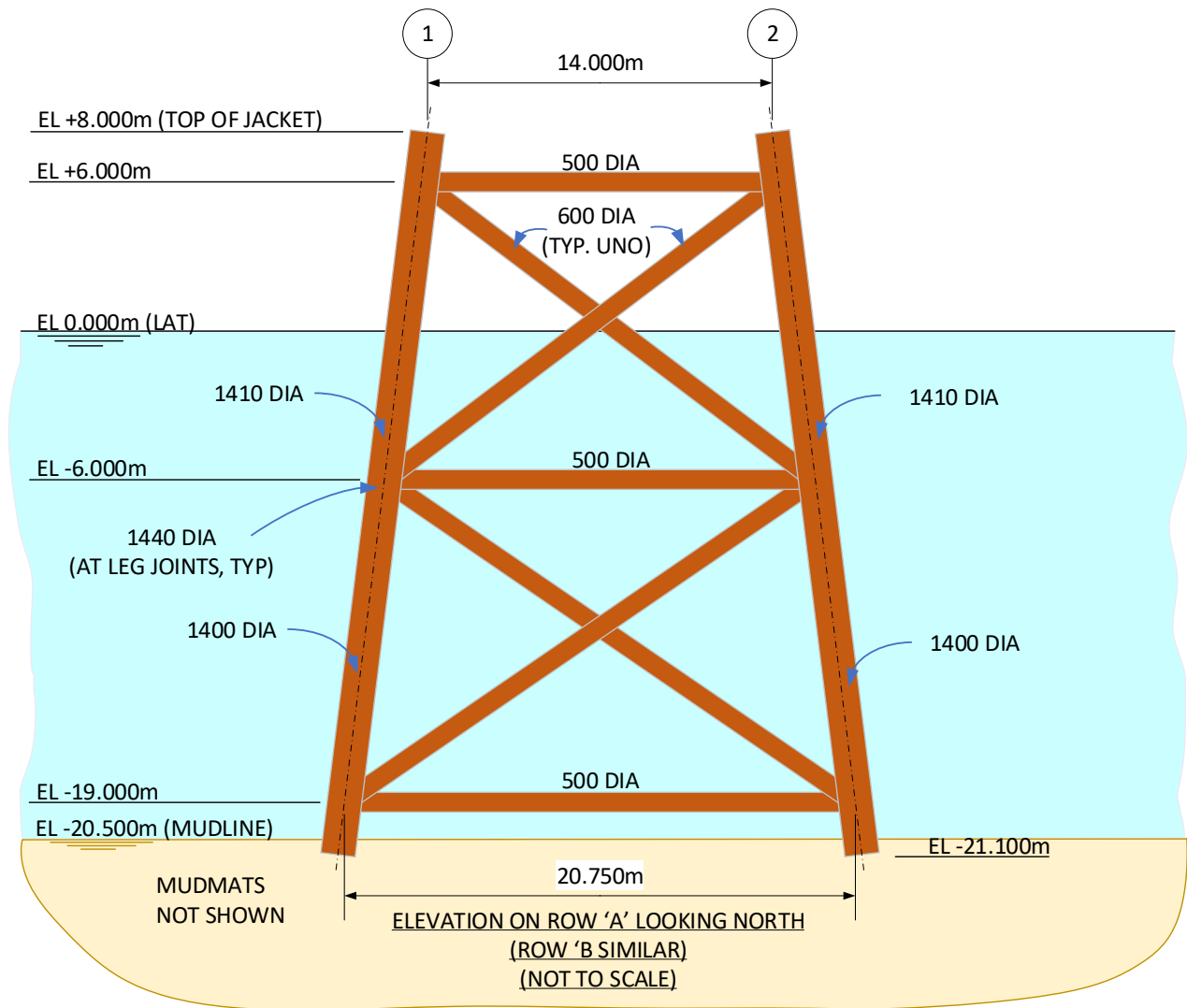

Figure 3.2.7: North Valiant PD Jacket View Looking North

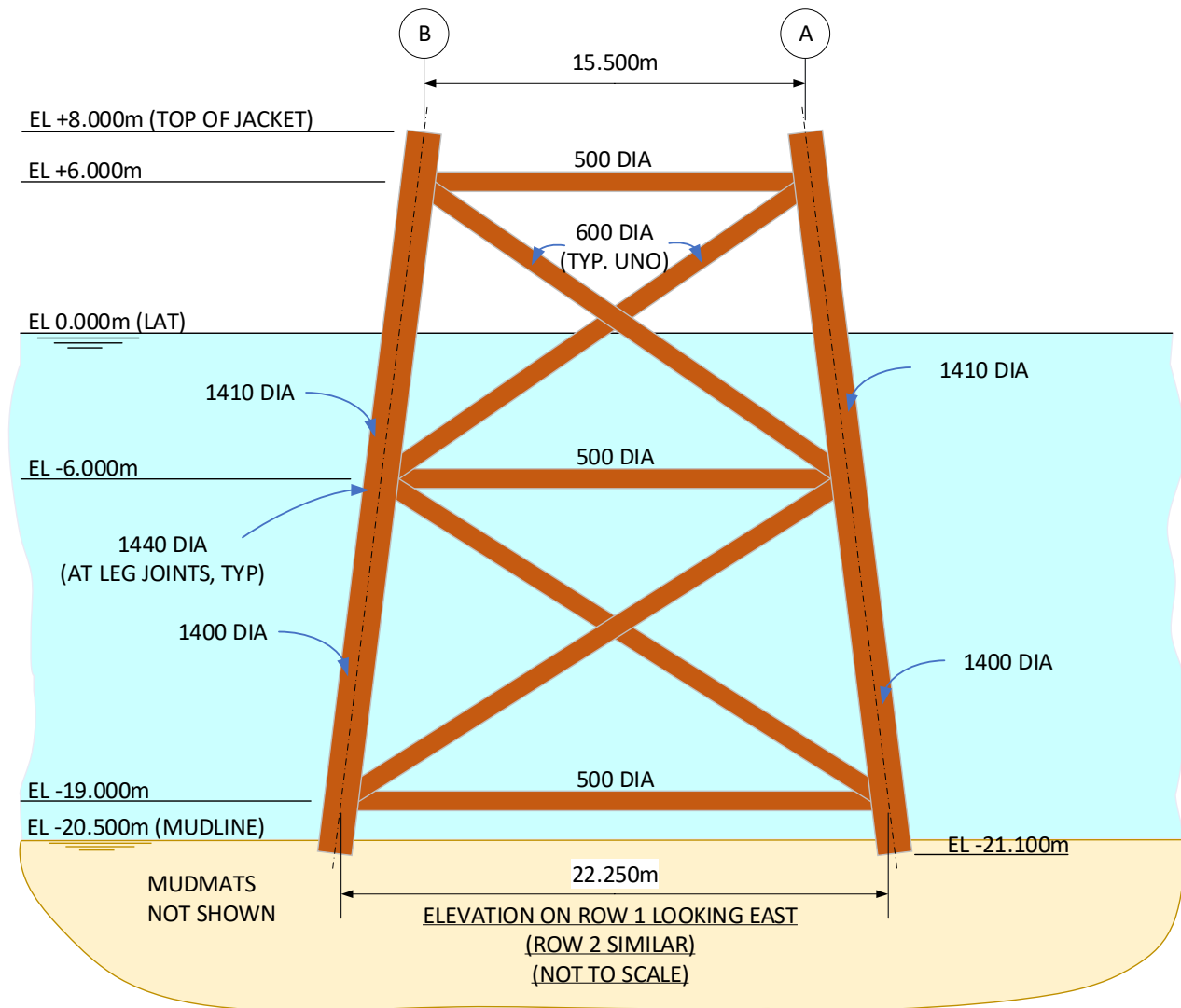

Figure 3.2.8: North Valiant PD Jacket View Looking East

3.2.6 Jacket Removal Methods

Table 3.2.1: Jacket Removal Methods	
1) Semi-Submersible Crane Vessel <input checked="" type="checkbox"/> ; 2) Monohulled Crane Vessel <input checked="" type="checkbox"/> ; 3) Shear Leg Vessel <input checked="" type="checkbox"/> ; 4) Jack up Work barge <input type="checkbox"/> ; 5) Complete with topsides <input checked="" type="checkbox"/>	
Methods Considered	Description
Single lift removal along with topsides using SSCV.	Removal of the topsides and jacket as a complete unit followed by recovery to shore for re-use, recycling, and disposal as appropriate.
Single lift removal using SSCV.	Removal of the jacket as a single unit followed by recovery to shore for re-use, recycling, disposal as appropriate.
Offshore removal 'piece-small' for onshore disposal	Removal of jacket and dismantlement offshore followed by transportation to shore for disposal and recycling.
Proposed removal method and disposal route	Removal of jacket as a single unit followed by recovery to shore for re-use, recycling, and final disposal to landfill as appropriate. A final decision on the decommissioning method was made following a commercial tendering process and the removal contract has now been awarded. Removal will be carried out using an SSCV.

3.3 Pipelines

3.3.1 Decommissioning Options

All exposed pipelines or pipespools on approach to LOGGS PP associated with the scope this Decommissioning Programme will be completely removed. That is, all pipelines buried under concrete mattresses that would otherwise be exposed will be removed.

Having carried out a pre-screening exercise of ten potential decommissioning options for the pipelines. The following options were retained for the comparative assessment and were considered applicable to the pipelines listed in Table 3.3.1:

- Option 1a: Leave *in situ*;
- Option 2a: Leave *in situ* with placement of rock over exposed lengths of pipeline;
- Option 4: Partial Removal remove short exposed lengths of pipe using the 'cut and lift' method;
- Option 6: Full Removal using the 'cut and lift' method.

Table 3.3.1: Pipeline or Pipeline Groups / Decommissioning Options			
Pipelines Group 1	Condition of line / group (Surface laid/Trenched/Buried/Spanning)	Whole or part of pipeline/group	Decommissioning Options considered
Pipelines Group 3b			
PL454	Trenched and buried in the seabed throughout the length of the pipeline albeit with exposures and freespans (refer Table 2.2.1) except on approach at LOGGS PP, on approach to the branch tees, the pipeline crossings and the transitions where the pipeline is buried under deposited rock. There is one reportable span near the PL2810 12" Clipper South RL gas export & PL2811 3" MeOH pipeline crossing that has developed fairly recently.	Whole 36" pipeline, except for short exposed lengths of welded pipespools on approach to LOGGS PP. Refer Figure 2.3.7.	1a, 2a, 4 & 6
PL455	Trenched and buried in the seabed throughout the length of the pipeline albeit with exposures and freespans (refer Table 2.2.1) except on approach at LOGGS PP, the pipeline crossings and at transitions where the pipeline is buried under deposited rock.	Whole 4" pipeline, except for short exposed lengths of flexible pipespools on approach to LOGGS PP. Refer Figure 2.3.7.	1a, 2a, 4 & 6

3.3.2 Outcomes of Comparative Assessment

A comparative assessment of the decommissioning options was carried out in accordance with the OPRED Decommissioning guidance notes. Each decommissioning option was assessed against Safety, Environment, Technical and Societal and Cost using the pair-wise comparison technique. Refer [4] for details.

The chosen option is 'leave *in situ*'. The influence of existing infrastructure that had been removed could affect the mobility local seabed. In order to minimise the deposition of additional rock, and to minimise any potential increase in snagging hazards, for example, by removing intermediate exposures or spans, it was considered that leave *in situ* would be appropriate. The means that the pipelines would meantime remain as they are, and any existing reportable spans would remain recorded in FishSAFE. Use of historical pipeline survey data with future pipeline surveys would better inform the future strategy for monitoring the pipelines.

Table 3.3.2: Outcomes of Comparative Assessment		
Pipeline or Group	Recommended Option	Justification
PL454	At LOGGS PP cut at each end of the exposed length – that is, where it emerges from the	The pipeline is stable for much of its length albeit with several km of

Table 3.3.2: Outcomes of Comparative Assessment

Pipeline or Group	Recommended Option	Justification
	<p>deposited rock and at the riser. Completely remove the resulting length of 36” pipeline (~25m long). Up to 25Te of rock will be deposited over the cut ends of the pipeline being left <i>in situ</i>.</p> <p>Completely remove the pipeline inside trench (~15m long) and protection structures associated with branch tee Nos. 1 and 2. Refer Figure 2.3.2 and Figure 2.3.3. Bury the remaining cut ends by depositing up to 25Te of loose rock. The area of seabed vacated by the branch tee structures and associated section of pipeline will be left to back-fill naturally.</p> <p>Therefore, except for the removal of the sections of pipeline underneath the branch tees and the two branch tees at KP26.2 and KP51.6, the pipeline will be left <i>in situ</i> in its current state.</p> <p>The pipeline will be subject to inspection and monitoring to a schedule agreed with OPRED.</p>	<p>exposures and some spans (refer Table 2.2.1).</p> <p>This will result in minimal seabed disturbance, avoids the deposition of additional rock on exposed sections of the pipeline in a sensitive area, lower energy use, and reduced risk to personnel and lower cost; all these aspects contribute to the proposed recommendation.</p> <p>Refer Appendix 1.1 for burial profile.</p>
PL455	<p>At LOGGS PP sever the pipeline where it emerges from the deposited rock and cut at the riser interface. Cut the 4” flexible pipespool at each end of its exposed length – that is, where it enters the deposited rock and at the riser, and completely remove the resulting pipespool (~39m long).</p> <p>The cut ends of the pipeline being left <i>in situ</i> will be covered using the same rock used for PL454.</p> <p>Therefore, except for the removal of the exposed end the pipeline will be left <i>in situ</i> in its current state.</p> <p>The pipeline will be subject to inspection and monitoring to a schedule agreed with OPRED.</p>	<p>Albeit with some exposed sections (refer Table 2.2.1), the pipeline is buried and stable for most of its length except for the end at LOGGS PP.</p> <p>This will result in minimal seabed disturbance, avoids the deposition of additional rock on exposed sections of the pipeline, lower energy use, and reduced risk to personnel and lower cost; all these aspects contribute to the proposed recommendation.</p>

3.4 Pipeline Protection Structures & Stabilisation Features

Table 3.4.1: Subsea Pipeline Protection Structures & Stabilisation Features

Protection or Stabilisation Features	Number (UNO)	Description	Disposal Route (if applicable)
Branch Tee No. 1	1	Protection frame for Branch Tee at KP26.2 c/w valves and pipework contained within (Figure 2.3.2)	Fully recover to shore for recycling or disposal. If stabilisation material is disturbed, it is to be removed. If stabilisation material is visible and no longer serves a purpose it is to be fully removed. Deposited rock will be left <i>in situ</i>
Bitumen mattresses ¹	20	18x M1 bitumen mattress (3.69m x 2.36m x 0.45m) 2x M2 bitumen mattress (4.62m x 2.46m x 0.45m)	
Deposited rock	811Te	Branch Tee between KP26.176 to KP26.212	
Branch Tee No. 2	1	Protection frame for Branch Tee at KP26.2 c/w valves and pipework contained within (Figure 2.3.3)	
Bitumen mattresses	20	8x M1 bitumen mattress (3.69m x 2.36m x 0.45m) 12x M2 bitumen mattress (4.62m x 2.46m x 0.45m)	
Deposited rock	758Te	Branch Tee between KP51.591 to KP51.598	

NOTES:

1. Bitumen mattress M1 & M2 sizes:
 - a. M1 = 3.69m x 2.46m x 0.45m;

Table 3.4.1: Subsea Pipeline Protection Structures & Stabilisation Features			
Protection or Stabilisation Features	Number (UNO)	Description	Disposal Route (if applicable)
b. M2 = 4.62m x 2.46m x 0.45m.			

3.5 Pipeline Protection & Stabilisation Features

Table 3.5.1: Pipeline Protection & Stabilisation Features			
Protection or Stabilisation Features	Number (UNO)	Description	Disposal Route (if applicable)
Concrete mattresses (underneath or on top of pipelines)	2	LOGGS PP Approach (PL454 & PL455), 10m x 5m x 0.15m. Refer Figure 2.3.7	Leave buried scour protection mattresses <i>in situ</i> .
	5	LOGGS PP approach (PL454 & PL455), 6m x 3m x 0.15m. Refer Figure 2.3.7	
	72	PL253 pipeline crossing. Refer Figure 2.3.4	Leave <i>in situ</i> underneath deposited rock
	31	PL27 & PL161 pipeline crossings. Refer Figure 2.3.5	
Grout bags (1Te)	16	LOGGS PP approach (PL454 & PL455), 4x4 1Te grout bags at four locations. Refer Figure 2.3.7	Fully recover all exposed 1Te grout bags. For the purpose of inventory, it is assumed that all the 1Te (or equivalent) grout bags will be recovered.
Grout bags (25kg)	120	LOGGS PP approach, in between 4x 6m x 3m mattresses underneath PL454 & PL455. Refer Figure 2.3.7	Leave any grout bags between the buried mattresses <i>in situ</i> .
	133	LOGGS PP approach, in between 10m x 5m mattresses east of PL454 & PL455. Refer Figure 2.3.7	
	33	LOGGS PP approach, north-south in between 4x 6m x 3m mattresses and 10m x 5m mattresses east of PL454 & PL455. Refer Figure 2.3.7	
Deposited rock	88,364Te	Various location. Refer Table 2.3.4	Deposited rock will be left <i>in situ</i>
NOTES:			

3.6 Wells

Table 3.6.1: Well Decommissioning

The North Valiant PD wells listed in Section 2.4, Table 2.4.1 have already been decommissioned.

3.7 Waste Streams

Table 3.7.1: Waste Stream Management Method

Waste Stream	Removal and Disposal Method
Bulk liquids	Residual hydrocarbons have already been removed from topsides. Further cleaning and decontamination will take place onshore prior to re-use or recycling.
Marine growth	Where necessary and practicable, to allow access some marine growth will be removed offshore. The remainder will be brought to shore and disposed of according to guidelines and company policies.
NORM	Tests for NORM have been undertaken offshore by the Radiation Protection Supervisor. and recorded. Any NORM encountered onshore will be dealt with and disposed of in accordance with guidelines and company policies and under appropriate permit.
Asbestos	Given the age of the installations asbestos can be expected and will be dealt with and disposed of in accordance with guidelines and company policies.
Other hazardous wastes	Other hazardous waste will be recovered to shore and disposed of according to guidelines and company policies and under appropriate permit.
Onshore dismantling sites	Appropriate licensed sites will be selected. The dismantling site must demonstrate proven disposal track record and waste stream management throughout the deconstruction process and demonstrate their ability to deliver re-use and recycling options.

Table 3.7.2: Waste Stream Management Methods

Asset	Inventory	Total (Te)	Planned Materials to Shore (Te)	Planned Materials Decommissioned <i>in situ</i> (Te)
LOGGS Installation & Pipelines	Installation	23,314	20,546	2,768
	Pipelines	150,222	946	149,276
	Deposited Rock	89,194	-	89,194

4 Environmental Appraisal Overview

4.1 Environmental Sensitivities (Summary)

Table 4.1.1: Environmental Impact Management	
Environmental Receptor	Main Features
Conservation interests	<p><u>Sites of Conservation Importance</u></p> <p>The LOGGS infrastructure included within the scope of the Decommissioning Programmes is located within three sites of conservation importance: the North Norfolk Sandbanks and Saturn Reef SAC, the Southern North Sea SAC while the trunk pipeline itself also passes through the Inner Dowsing, Race Bank and North Ridge SAC.</p> <p>The North Norfolk Sandbanks and Saturn Reef SAC site has been selected for designation due to the presence of the Annex I habitats: sandbanks that are slightly covered by water at all times, and biogenic reef habitats formed by Sabellaria spinulosa. The Conservation Objectives for the North Norfolk Sandbanks and Saturn Reef SAC are for the features to be in favourable condition, thus ensuring site integrity in the long term and contribution to Favourable Conservation Status of Sandbanks and Reefs. This contribution would be achieved by maintaining or restoring, subject to natural change:</p> <ul style="list-style-type: none"> • The extent and distribution of the qualifying habitats in the site; • The structure and function of the qualifying habitats in the site; and • The supporting processes on which the qualifying habitats rely. <p>The Southern North Sea SAC has been identified as an area of importance for the Annex II species the harbour porpoise. This site includes key winter and summer habitat for this species. The Conservation Objectives of the site are to ensure that the integrity of the site is maintained and that it makes the best possible contribution to maintaining Favourable Conservation Status for Harbour Porpoise in UK waters. In the context of natural change, this will be achieved by ensuring that:</p> <ul style="list-style-type: none"> • Harbour porpoise is a viable component of the site; • There is no significant disturbance of the species; and • The condition of supporting habitats and processes, and the availability of prey is maintained. <p>Annex II species likely to be sighted within the area of the proposed decommissioning activities include bottlenose dolphins, harbour porpoise, grey seals and common or harbour seals (Environmental Appraisal report [3], Section 4.3 [3]).</p> <p>The Inner Dowsing, Race Bank and North Ridge SAC is designated for sandbanks slightly covered by water at all times and for reefs. The area encompasses a wide range of sandbank types (banks bordering channels, linear relict banks, sinusoidal banks with distinctive 'comb-like' subsidiary banks) and biogenic reef of the worm Sabellaria spinulosa. The Conservation Objectives for this SAC are for the features to be in favourable condition, thus ensuring site integrity in the long term and contribution to Favourable Conservation Status of Sandbanks and Reefs.</p> <p>The length of pipeline lying within the Inner Dowsing, Race Bank and North Ridge SAC is 19.32 km.</p>

Table 4.1.1: Environmental Impact Management

Environmental Receptor	Main Features
	<p><u>Marine Conservation Zones (MCZs)</u> The installations and pipelines included within the scope of the Decommissioning Programmes do not transect any MCZs.</p> <p><u>Special Protection Areas (SPAs)</u> The trunk pipelines included within the scope of the Decommissioning Programmes transect the Humber Estuary and Greater Wash SPAs. The LOGGS to TGT pipeline crosses the Humber Estuary SPA for 0.36 Km and crosses the Greater Wash SPA for 25.9km.</p>
Seabed	<p>The seabed near the LOGGS infrastructure is predominantly composed of sand with shells and shell fragments, with some gravel and cobbles. Sediments are generally well sorted and uniform. The Bathymetry across the area is relatively flat with mega-ripples and sand formations (Environmental Appraisal report [3], Section 4.1). There is no evidence of bedrock, pockmarks or unusual or irregular bedforms. The infaunal community is generally dominated by crustacea and polychaete worms. The species are typical of the sandy sediments of southern North Sea. Whilst epifauna are generally sparse across the area due to the lack of hard substrata, polychaete worms, hermit crabs, fish including sand eels and flatfish, starfish including the common starfish and the sea star, and the soft coral dead mans' fingers are all observed. In terms of habitat classification, most stations within the associated pre-decommissioning baseline survey were categorised as 'infralittoral fine sand', which corresponds to clean sands occurring in shallow water (generally shallower than 20m), either on open coast or in tide swept channels of marine inlets. This is consistent with the protected Annex I habitat 'sandbanks slightly covered by seawater all the time'. There is a high probability of Sabellaria spinulosa across the region. A small fragment of tube structure recovered in a sieve during sampling at the Ganymede ZD location was considered to have possibly been made by the Ross worm Sabellaria spinulosa aggregations of such tubes can sometimes create reef structures which are of conservation concern. However, no Sabellaria spinulosa were evident either as individuals or as tube aggregations from the survey, and none of the geophysical data suggested the presence of such structures. Seabed imagery did not provide any evidence of any threatened and/or declining species and habitats on the OSPAR (2008) list or any species on the International Union for Conservation of Nature Global Red List of threatened species [7][8].</p>
Fish	<p>The area is located within the spawning grounds of various species including:</p> <ul style="list-style-type: none"> • cod (January to April; [peak spawning February to March]); • lemon sole (April to September); • Norway lobster (January to December [peak spawning April to June]); • plaice (December to March [peak spawning January to February]); • sandeels (November to February); • sole (December and March to May [peak spawning in April]);

Table 4.1.1: Environmental Impact Management

Environmental Receptor	Main Features
	<ul style="list-style-type: none"> • sprat (May to August [peak spawning May to June]); • thornback ray (February to September [peak spawning April to August]); and, • whiting (February to June). <p>Within the area of facilities and infrastructure being decommissioned there is an area of high intensity spawning for plaice. The following species have nursery grounds in the vicinity of the decommissioning works: anglerfish, cod, herring, lemon sole, plaice, sandeel, sprat, mackerel, spurdog, herring, Norway lobster, sole, tope, thornback ray and whiting. Within the decommissioning area is an area of high intensity nursery grounds for cod, herring and whiting.</p>
Fishing Industry	<p>Across wider LOGGS Area (North and South), fishing grounds are fished at varying degrees by the following fleets [6]:</p> <ul style="list-style-type: none"> • Dutch beam trawlers, demersal otter trawlers, and fly seiners; • UK potters, shrimp beam trawlers, shellfish dredgers, otter trawlers, long-liners, and netters; • Belgian beam trawlers and demersal otter trawlers; • Danish sandeelers, midwater and demersal trawlers and seine netters; • Norwegian purse seiners and midwater otter trawlers; • German beam trawlers and demersal otter trawlers; • French otter trawlers (demersal and pelagic); and, • French purse seine netters. <p>The main species targeted are shellfish, with demersal species dominate catch in some areas. The highest number of effort days takes place in the summer months (July-September). Activity is low to moderate except at the Europa platform where fishing intensity is higher (Environmental Appraisal report [3], Section 4.5).</p>
Marine mammals	<p>Cetaceans regularly recorded in the North Sea include the harbour porpoise, bottlenose dolphin, minke whale, killer whale, Atlantic white-sided dolphin, and white-beaked dolphin. Rarer species that are occasionally observed in the North Sea include fin whale, long-finned pilot whale, Risso's dolphin and the short beaked common dolphin. However, harbour porpoise and white-beaked dolphin are the only cetaceans considered as regular visitors in the Southern North Sea throughout most of the year, and minke whale as a frequent seasonal visitor (Environmental Appraisal report [3], Section 4.3.1).</p> <p>Pinnipeds sighted in the area include grey seals, and harbour seals. Grey seals may travel past the infrastructure towards foraging grounds, but densities generally reduce with distance offshore. Harbour seals are more likely to be sighted further offshore, travelling to this area from breeding and haul out sites in The Wash to forage for food (Environmental Appraisal report [3], Section 4.3.2).</p>
Birds	<p>The most common species of seabird found in these areas of the SNS include fulmar, gannet, guillemot, kittiwake, razorbill, puffin, and little auk, as well as numerous species of gull, tern and skua.</p> <p>In the decommissioning area the sensitivity of seabirds to oil pollution, reflected by the Seabird Oil Sensitivity Index, is low between July and September.</p> <p>Between November and March, the Seabird Oil Sensitivity Index is very high to extremely high. There is no data for April to June for many of the blocks, and again for October and November.</p>

Table 4.1.1: Environmental Impact Management	
Environmental Receptor	Main Features
Onshore communities	An onshore decontamination and dismantlement facility will be used that is deemed able to comply with all relevant permitting and legislative requirements.
Other users of the sea	<p><u>Shipping</u> Shipping density in the area of the infrastructure to be decommissioned ranges from very low to high. The main contributing factor of very high vessel density in the area closer to shore is the number of large international ports within the region including Hull, Immingham, Grimsby and Great Yarmouth (Environmental Appraisal report [3], Section 4.7).</p> <p><u>Oil & Gas Industry</u> The infrastructure is located in the SNS gas basin which is densely populated by various installations. Please refer Table 1.6.1, Figure 1.6.3 and Figure 1.6.4 for information regarding adjacent facilities.</p> <p><u>Offshore Renewables</u> The nearest windfarms are Hornsea zone and East Anglia zone located approximately 35km N and SE from LOGGS facilities respectively, and the Dudgeon windfarm site which is located approximately 36km W.</p>
Atmosphere	Atmospheric emissions during decommissioning activities will occur in the context of the cessation of production. As such, almost all future emissions (from project operations and vessels) will cease (Environmental Appraisal report [3], Section 3.1).

4.2 Potential Environmental Impacts and their Management

4.2.1 Environmental Impact Assessment Summary

The potential environmental impacts associated with the decommissioning activities have been assessed and it is concluded that the proposed decommissioning of the infrastructure can be completed without causing significant adverse impact to the environment. The EA assesses the potential environmental impacts by identifying interactions between the proposed decommissioning activities and the associated environmental receptors. It also describes the proposed mitigation measures designed to avoid or reduce the identified potential environmental impacts and how these will be managed in accordance with Chrysaor's Environmental Management System (EMS) while considering responses from stakeholders.

Table 4.2.1: Environmental Impact Management

Activity	Main Impacts	Management
Topsides removal	Energy use and atmospheric emissions	All engines, generators and combustion plant on the vessels will be well maintained and correctly operated to ensure that they are working efficiently to minimise energy use and gaseous emissions. Vessel operations will be minimised where practical.
	Underwater noise	A noise assessment has been completed to determine the likely impact of noise generated by the proposed operations on marine mammals in the surrounding area. The results of the assessment will be used during the planning of vessel operations.
	Accidental hydrocarbon release	Hydrocarbon inventories are to be removed from the topsides prior to commencing removal operations. The SNS Oil Pollution Emergency Plan has been updated in agreement with OPRED to include all planned decommissioning operations.
Jacket removal	Energy use and atmospheric emissions	All engines, generators and combustion plant on the vessels will be well maintained and correctly operated to ensure that they are working efficiently to minimise energy use and gaseous emissions. Vessel operations will be minimised where practical.
	Underwater noise	A noise assessment has been completed to determine the likely impact of noise generated by the proposed operations on marine mammals in the surrounding area. The results of the assessment will be used during the planning of vessel operations. There is no intention to use underwater explosives during these activities.
	Accidental hydrocarbon release	The SNS Oil Pollution Emergency Plan has been updated in agreement with OPRED to include all planned decommissioning operations.
	Seabed disturbance and loss of habitat	The decommissioning operations will be carefully designed and executed to minimise the area of seabed that will be disturbed. Loss of habitat through the introduction of new material to the marine environment is to be avoided or minimised throughout the proposed operations.

Table 4.2.1: Environmental Impact Management

Activity	Main Impacts	Management
Pipeline decommissioning	Energy use and atmospheric emissions	All engines, generators and combustion plant on the vessels will be well maintained and correctly operated to ensure that they are working efficiently to minimise energy use and gaseous emissions.
	Underwater noise	A noise assessment has been completed to determine the likely impact of noise generated by the proposed operations on marine mammals in the surrounding area. The results of the assessment will be used during the planning of vessel operations.
	Seabed disturbance and loss of habitat	The operations to remove the pipeline ends will be carefully designed and executed to minimise the area of seabed that will be disturbed. Loss of habitat through the introduction of new material to the marine environment is to be avoided or minimised throughout the proposed operations. The resulting rock berm profile will be overtrawlable.
	Discharges to sea	The pipelines have already been flushed in readiness for severance. A chemical risk assessment will be undertaken, and operations permitted under the Offshore Chemicals Regulations 2002 (as amended). Hydrocarbon discharges during subsea pipeline disconnect operations will be permitted under the Offshore Petroleum Activities (Oil Pollution Prevention and Control) Regulations 2005 (as amended). Residual hydrocarbons, scale and sediments will be released gradually after through-wall corrosion occurs and the integrity of the pipelines progressively fails. Through-wall degradation is anticipated to begin to occur after many decades (i.e. 60 – 100 years). Pathways from the pipelines to the receptors would be via the interstitial spaces in seabed sediments, overlying deposited rock - where applicable, and the water column. Release would therefore be gradual and prolonged such that the effects on the receiving marine environment are negligible.
	Physical presence of infrastructure decommissioned <i>in situ</i> . Snagging hazard of exposed sections of pipeline remaining <i>in situ</i> .	The seabed footprint of infrastructure to be decommissioned <i>in situ</i> including the trunk pipelines is estimated as 2.4 km ² , 0.4 km ² of which will be within Southern North Sea SAC, 0.5 km ² of which will be within the North Norfolk Sandbanks and Saturn Reef SAC, 0.4 km ² will be within the Inner Dowsing, Race Bank and North Ridge SAC, 0.01 km ² within the Humber Estuary SPA and 0.5 km ² within the Greater Wash SPA. This represent 0.21% of the total designated areas. Although it has been assessed that the introduction of additional deposited rock will not change the character of the species typically present in the area as a whole, decommissioning of mattresses and grout bags <i>in situ</i> is recommended, as this will reduce the amount of deposited rock required for remedial works. The presence of decommissioned pipelines will not compromise the integrity of the environmental feature of the seabed in the area. Pipelines decommissioned <i>in situ</i> will continue to be shown on Navigational charts.

Table 4.2.1: Environmental Impact Management		
Activity	Main Impacts	Management
Decommissioning of protection and stabilisation features	Physical presence of infrastructure decommissioned <i>in situ</i> . Snagging hazard of stabilisation feature associated with pipeline.	Stabilisation features associated with pipeline remain <i>in situ</i> . Full overtrawlability survey or alternative non-invasive survey techniques owing to the environmental sensitivities of the area in the 500m zone where stabilisation features predominantly exist and at locations beyond the 500m zone where exposed mattresses are identified. The presence of decommissioned stabilisation features will not compromise the integrity of the environmental feature of the seabed in the area. Stabilisation features are inherently overtrawlable by design.

5 Interested Party Consultations

Table 4.2.1: Summary of Stakeholder Comments		
Stakeholder	Comment	Response
STATUTORY CONSULTATIONS		
NFFO		
NIFPO		
SFF		
GMG		
Public		

6 Programme Management

6.1 Project Management and Verification

Chrysaor has established a UK Decommissioning organisation as a department to manage and execute decommissioning projects. Chrysaor's existing processes for Operations, Planning, Project Management, Procurement, Health Safety and Environment, will be used and tailored to meet the specific requirements of decommissioning projects. Chrysaor will manage all permitting, licences, authorisations, notices, consents and consultations.

Any changes to this decommissioning document will be discussed and agreed with OPRED.

6.2 Post-Decommissioning Debris Clearance and Verification

Verification of seabed state will be obtained. Whilst the worst-case seabed disturbance from overtrawl has been assessed, it is recognised that some of the decommissioning activities is occurring in the North Norfolk Sandbanks and Saturn Reef SAC, therefore different methods of determining debris clearance and snag risk may be required. The methods used will therefore be discussed and finalised with OPRED. This will be followed by a statement of clearance to all relevant governmental departments and statutory consultees.

Oil and gas debris activity and verification along the remaining pipeline corridor of the infield pipeline sections not subject to actual decommissioning works will be carried out in accordance with OPRED guidance in operation at the time those activities commence. This activity will reflect the environmental setting of the North Norfolk Sandbanks and Saturn Reef SAC.

The outcomes of the clear seabed verification activities in the 500m zones and the alternative survey methods of the pipelines will be reported in the Close Out Report and sent to the Seabed Data Centre (Offshore Installations) at the Hydrographic Office.

6.3 Schedule

A proposed schedule is provided in Figure 6.3.1. The activities are subject to the acceptance of the Decommissioning Programme presented in this document and any unavoidable constraints (e.g. vessel availability) that may be encountered while executing the decommissioning activities. Therefore, activity schedule windows have been included to account for this uncertainty.

The commencement of offshore decommissioning activities will depend on commercial agreements and commitments.

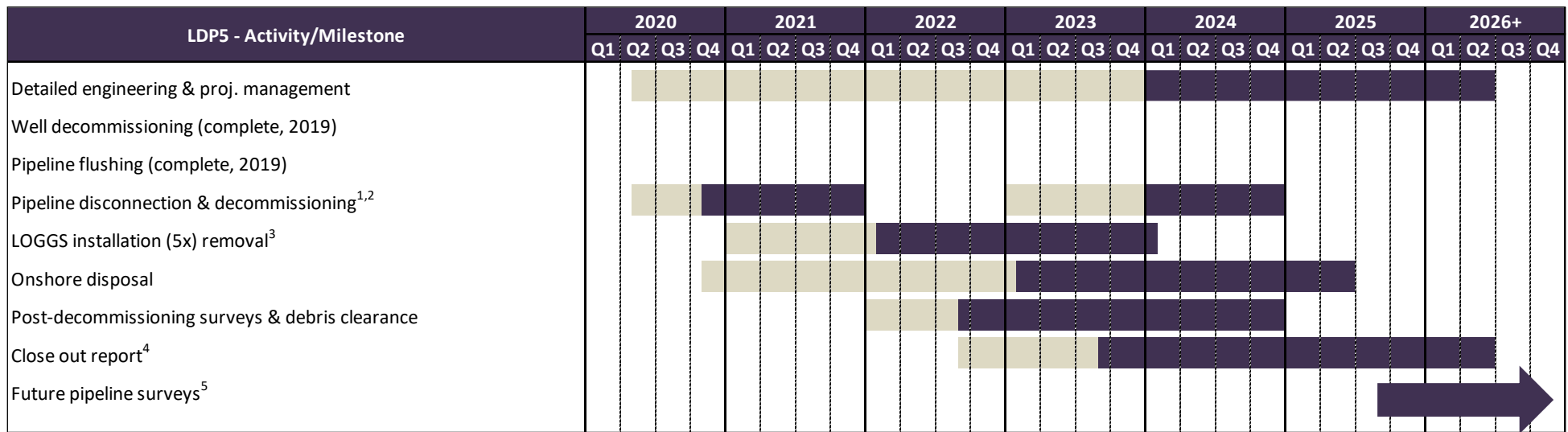

Notes / Key

Earliest potential activity 

Activity window to allow commercial flexibility associated with decommissioning activities 

1. Current intention is that all third party pipelines as well as PL454 & PL455 at the LOGGS Installation will be decommissioned in the same campaign;
2. LOGGS Trunkline Tees at KP26.2 & KP51.5 will be dealt with in a later campaign after removal of the installations;
3. Includes LOGGS PR, PP, PC, PA and North Valiant PD;
4. Close out report(s) will be prepared on completion of offshore activities. It will contain results of envtl survey, debris survey (identification/removal) and clear seabed verification survey;
5. Close out report(s) will explain the strategy based on risk assessments and results of post decommissioning surveys.

Figure 6.3.1: Gantt Chart of Project Plan

6.4 Costs

Decommissioning costs will be provided separately to OPRED and OGA.

6.5 Close Out

In accordance with OPRED guidelines, a close out report covering the completion of the offshore decommissioning scope of this Decommissioning Programme will be submitted at time agreed by OPRED. The close out report will contain debris removal and verification of seabed clearance, the first post decommissioning environmental survey and explanation of any variations to the approved Decommissioning Programmes.

6.6 Post Decommissioning Monitoring and Evaluation

After decommissioning activities have been concluded, pipeline status surveys and environmental surveys will be completed with the findings being sent to OPRED in the Close Out report. The frequency and scope of future surveys will be agreed with OPRED and supported by a risk assessment. Residual liability will remain with the Section 29 holders identified in Table 1.4.5. Unless agreed otherwise in advance with OPRED, Chrysaor will remain the focal point for such matters, such as any change in ownership, for example.

A post decommissioning environmental seabed survey will be carried out once the offshore decommissioning work scope covered by this decommissioning document has been completed. The survey will include seabed sampling to monitor levels of hydrocarbons, heavy metals, and other contaminants to allow for a comparison with the results of the pre-decommissioning survey. Results of this survey will be available once the decommissioning document work scope is complete.

PIPELINE RISK BASED MONITORING PROGRAMME

All pipeline systems covered within this Decommissioning Document scope will be subject to survey. The post decommissioning pipeline (and associated stabilisation features) monitoring programme, to be agreed with OPRED, will:

- Begin with an initial baseline survey covering the full length of each pipeline;
- Be followed by a risk-based assessment for each pipeline (and associated stabilisation materials) which will inform the minimum agreed extent and frequency of future surveying. This will take account of pipeline burial, exposure and spanning data derived from the initial baseline survey, all available historical survey information and fisheries impact assessment;
- Provide a report of each required survey (with analysis of the findings, the impact on the risk-based assessment and identification of the proposed timing of the next survey in accordance with the agreed RBA approach), for discussion and agreement of OPRED;
- Include provision for remediation in the framework where such a requirement is identified. Appropriate remediation will be discussed and agreed with OPRED;
- Where remediation has been undertaken, a follow up survey of the remediated section(s) will be required;
- In the event of a reported snagging incident on any section of a pipeline, the requirement for any additional survey and/or remediation, will be discussed and agreed with OPRED;
- Will include a further fisheries impact assessment following completion of the agreed survey programme;
- Monitoring will become reactive following completion of the agreed survey programme and OPRED agreement of the analysis of the outcomes;
- Require pipeline information to be recorded on Navigation charts and FishSAFE.

The monitoring programme will also include discussion with OPRED of the long-term pipeline degradation and potential risk to other users of the sea following conclusion of the planned survey programme.

7 Supporting Documents

- [1] Chrysaor (2020) LDP4 Decommissioning Programmes for LOGGS Satellites V fields Area & Associated Pipelines;
- [2] Chrysaor (2020) LDP2 Decommissioning Programmes for LOGGS Satellites Mimas (MN), Saturn (ND), Tethys (TN) & Associated Pipelines;
- [3] Chrysaor (2020) Environmental Appraisal LOGGS Area Decommissioning (Decommissioning Programmes LDP2, LDP3, LDP4, LDP5), XOD-SNS-L-XX-X-HS-02-00005;
- [4] Chrysaor (2020) Comparative Assessment Report LOGGS Area Decommissioning (Decommissioning Programmes LDP2, LDP3, LDP4, LDP5), XOD-SNS-L-XX-X-HS-02-00003;
- [5] ConocoPhillips (2017) Decommissioning Programmes for LOGGS Satellites Vulcan UR, Viscount VO, Vampire OD & Associated Infield Pipelines – LDP1. Weblink last accessed 28 August 2020: https://assets.publishing.service.gov.uk/government/uploads/system/uploads/attachment_data/file/64296/LDP1_Final.pdf
- [6] ConocoPhillips (2017). Commercial Fisheries Baseline Characterisation: LOGGS South, LOGGS North and CMS Areas. Report No. BMM-SNS-P-XX-S-HS-02-00001;
- [7] Gardline (2015). SNS Decommissioning Survey LOGGS Gas Fields (LOGGS Hub, Mimas MN, Ganymede ZD, South Valiant TD, Europa EZ). Habitat Assessment Report. August 2015. Report No. 10553.1;
- [8] Gardline (2015). SNS Decommissioning Survey LOGGS Gas Fields (LOGGS Hub, Mimas MN, Ganymede ZD, South Valiant TD, Europa EZ). Pre-decommissioning Survey Report. August 2015. Report No. 10553.2;
- [9] OPRED (2018) Offshore Oil and Gas Decommissioning Guidance Notes. Weblink last accessed 27 Jan 2020: https://assets.publishing.service.gov.uk/government/uploads/system/uploads/attachment_data/file/760560/Decom_Guidance_Notes_November_2018.pdf

Appendix 1 Pipeline Burial Profiles

Appendix 1.1 PL454 Seabed & Burial Profile (2010)

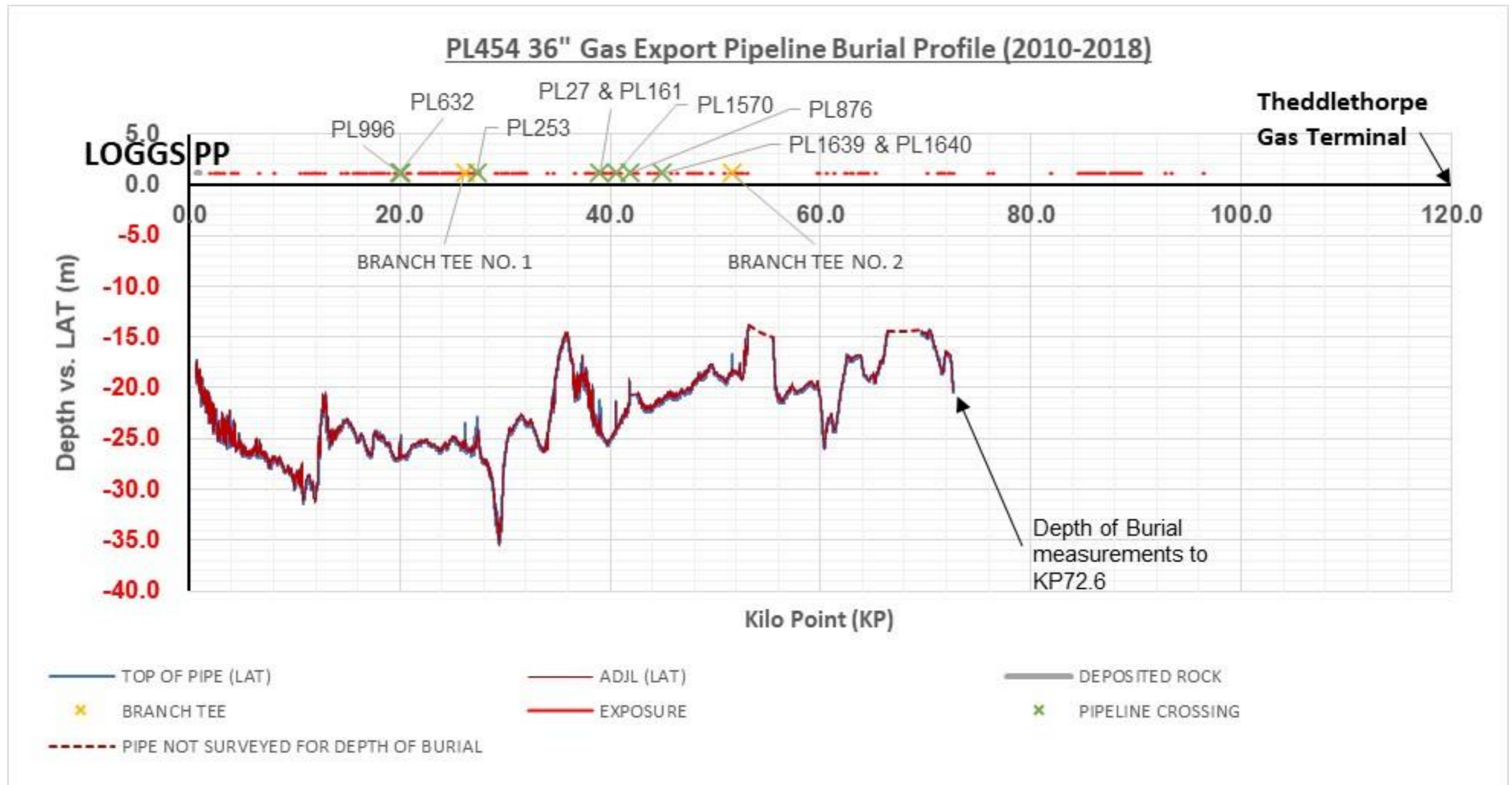

Figure A1.1.1: PL454 Seabed & Burial Profile (2010-2018)¹¹

¹¹Burial data only available up to ~KP72.6. Otherwise, gap in data due to shallow water over a sandbank; no survey data obtained. Note that >51,000 data points were used to construct the graph leading to a misrepresentation of the lengths of exposures. Please refer Table 2.2.1.

PL454 36" Gas Export Pipeline Burial Profile (2010-2018)

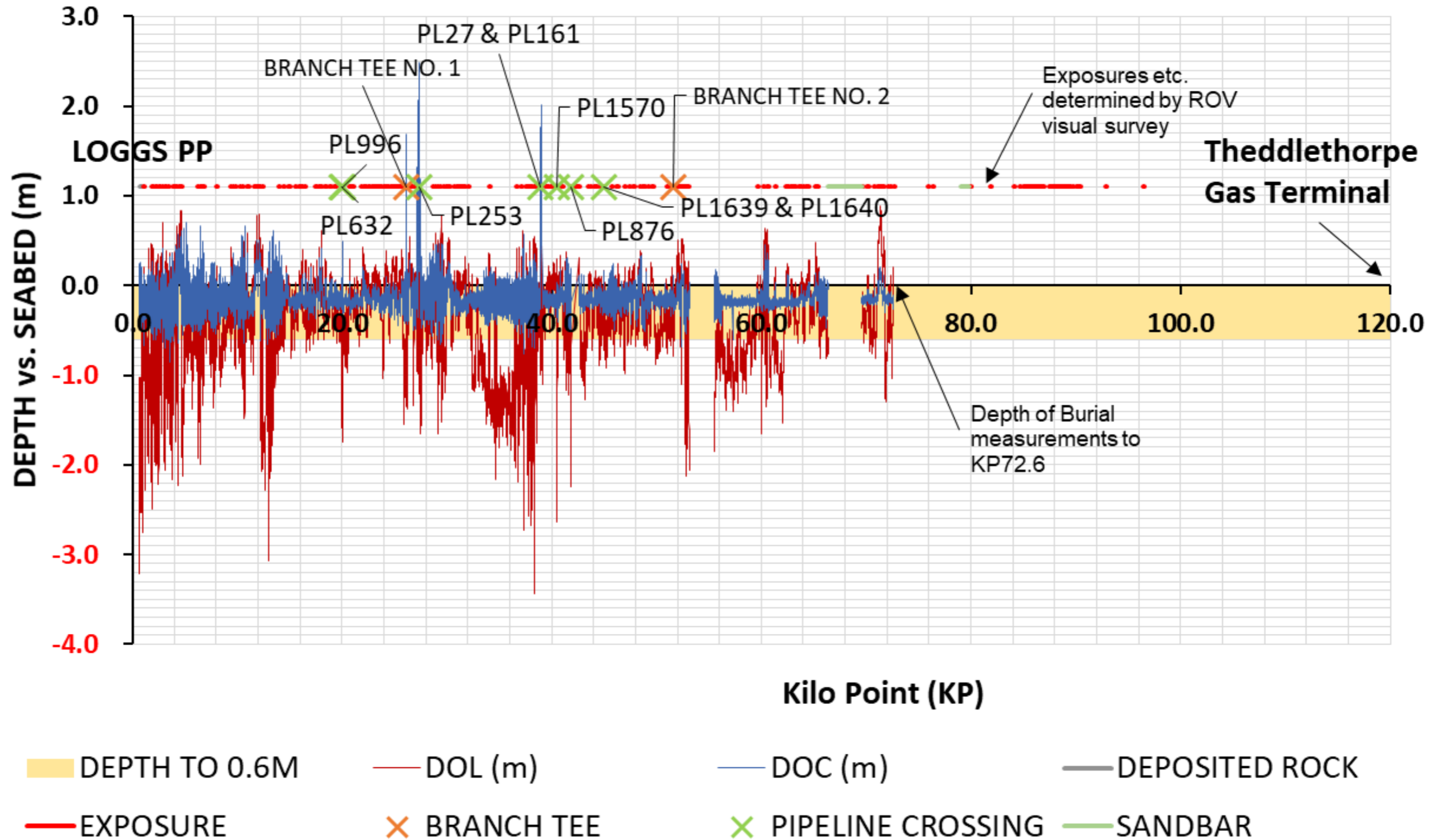

Figure A1.1.2: PL454 Depth of Cover Profile (2010-2018)¹¹

Appendix 2 Decommissioning Onshore Pipelines

Appendix 2.1 Outline Approach



Figure A2.1.1: PL454 Theddlethorpe Approach (indicative only)

The onshore pipelines will be decommissioned and abandoned in accordance with the Pipelines Act 1962, Regulations 25, the Pipelines Safety Regulations 1996, and the BSI Code of Practice for steel pipelines on land PD 8010-1:2015+A1:2016.

The pipelines will be flushed clean of hydrocarbons and toxic materials, then disconnected and sealed. The abandonment plan for the onshore sections of the pipelines out to the MLWM has not been fully defined. Where the pipelines are to be decommissioned *in situ*, they may be filled with a suitable filler and left buried. A record will be kept of all *in situ* pipelines indicating their contents, location, size, and depth of burial.

The option to use a suitable filler material for the onshore abandoned *in situ* pipeline sections would be based on an option selection assessment, as well as comprehensive stakeholder engagement.

Structural degradation of the pipelines will be a long-term process caused by corrosion and the eventual collapse of the pipelines under their own weight, the weight of the pipeline coating material and that of the overlying soil or substrate. It is anticipated that failure of the pipelines due to through-wall degradation would only begin to occur after many decades (i.e. 60 to 100 years) and is expected to take several hundred years to fully degrade.

During this process, degradation products derived from the exterior and interior of the pipe will breakdown and potentially become bioavailable in the immediate vicinity. Pathways from the pipelines to the receptors would be via the interstitial spaces in substrate.

The release of degradation products is expected to occur at a slow rate and therefore expected to have a minimal impact on the surrounding environment. The area that could be biologically impacted would likely be limited to a few metres on either side of the pipeline.

The primary degradation products will originate from the following pipeline components:

- Pipeline scale;
- Steel;
- Sacrificial anodes;
- Coal tar enamel coating;
- Concrete coating; and
- Plastic coating.

Complete failure of water filled buried pipelines has a potential for subsidence of the overlying substrate.

Appendix 3 Public & Consultee Correspondence

Appendix 3.1 Public Notices

Appendix 3.2 Correspondence with Statutory Consultees

Appendix 4 Partner Letters of Support